

BUYER'S MODEL NO. 087DW

FACTORY MODEL 087E0•087R0

ORIGINAL ISSUE July, 1995

SECTION —

REFER TO IMPORTANT NOTICE BELOW

PARTS LIST FOR

Model EPOCHLOCK • 087DW ELECTRONIC

AGUJA 705H

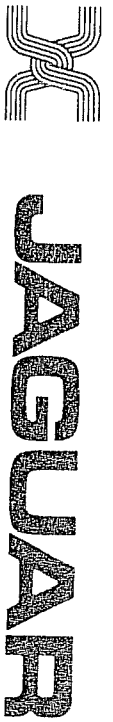
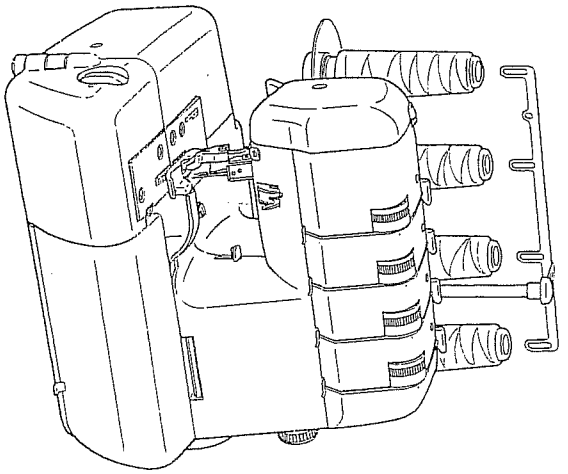

IMPORTANT:

WHEN ORDERING THE PARTS ALWAYS CHECK THE SERIAL NUMBER OF THE MACHINE.

FIRST DIGIT OF THE SERIAL NUMBER MUST MATCH WITH THE LAST DIGIT OF THE FACTORY MODEL ABOVE.

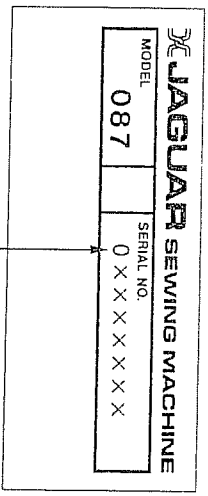

FIRST DIGIT

BUYER'S MODEL NO.	087 DW	SECTION		PAGE	1	REVISION		REMARKS	
BUYER'S MODEL NAME	EPOCHLOCK • 087 DW								
FACTORY MODEL	087E0 • 087R0								
ORIGINAL ISSUE	July, 1995	SERIAL NO.							

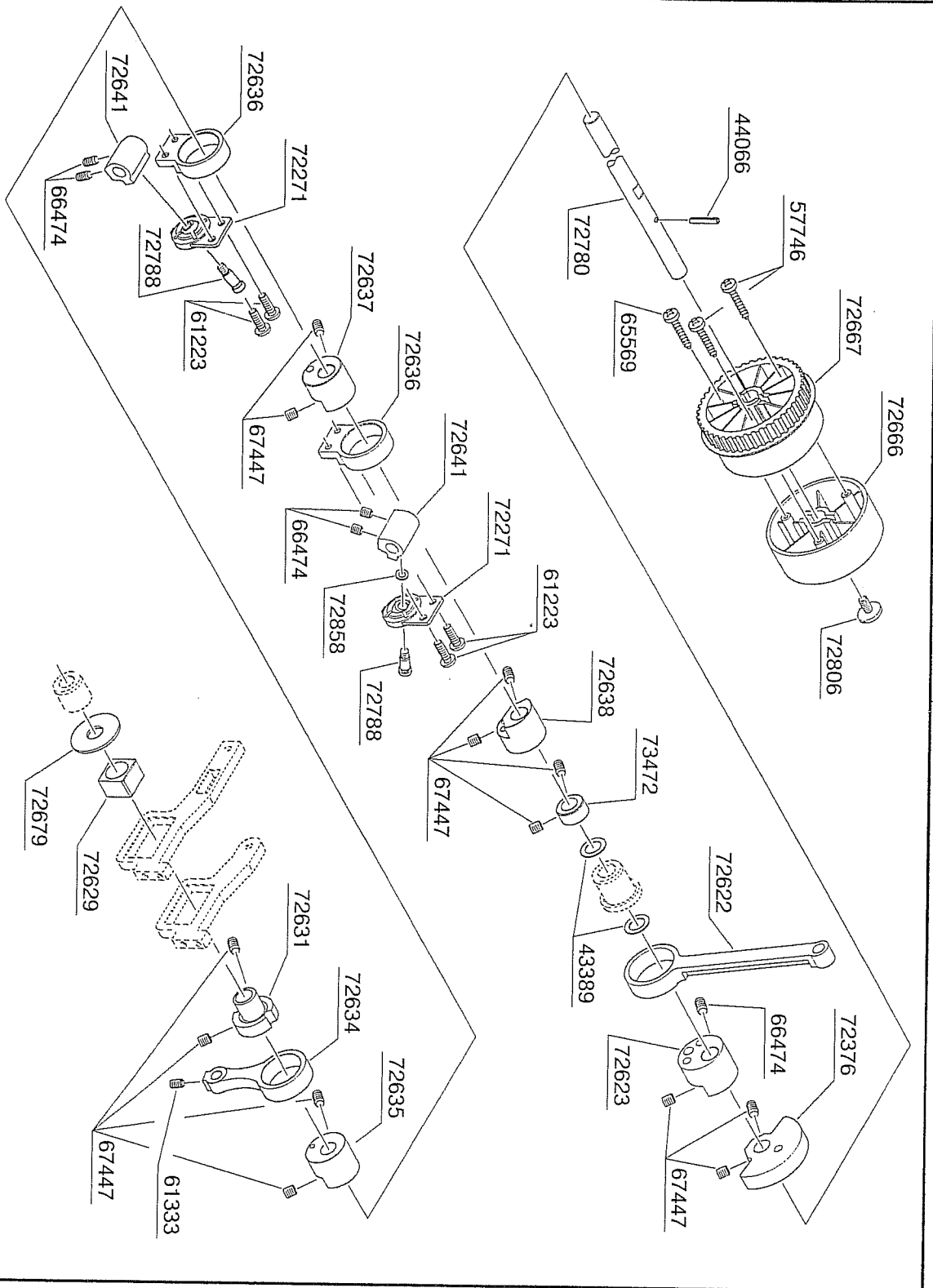

PART NO.	DESCRIPTION
43389	THRUST WASHER
44066	SPRING PIN
57746	TAPPING SCREW
61223	M4 PHILLIPS SCREW
61333	M4 SCREW
65569	TAPPING SCREW
66474	M5 SCREW
67447	M5 SCREW
72271	BALL JOINT
72376	BALANCE CAM
72622	CRANK ROD
72623	ECCENTRIC CAM
72629	SLIDE BLOCK
72631	ECCENTRIC CAM
72634	CRANK ROD
72635	ECCENTRIC CAM
72636	CONNECTING ROD END
72637	ECCENTRIC CAM
72638	ECCENTRIC CAM
72641	LOOPER DRIVING ARM
72666	HAND WHEEL
72667	BELT PULLEY
72679	NYLON WASHER
72780	MAIN SHAFT
72788	M4 STUD SCREW
72806	M5 SCREW
72858	WASHER
73472	COLLAR

BUYER'S MODEL NO.	087 DW	SECTION	PAGE	REVISION	REMARKS
BUYER'S MODEL NAME	EPOCHLOCK • 087DW		2		
FACTORY MODEL	087E0 • 087R0				
ORIGINAL ISSUE	July, 1995	SERIAL NO.			

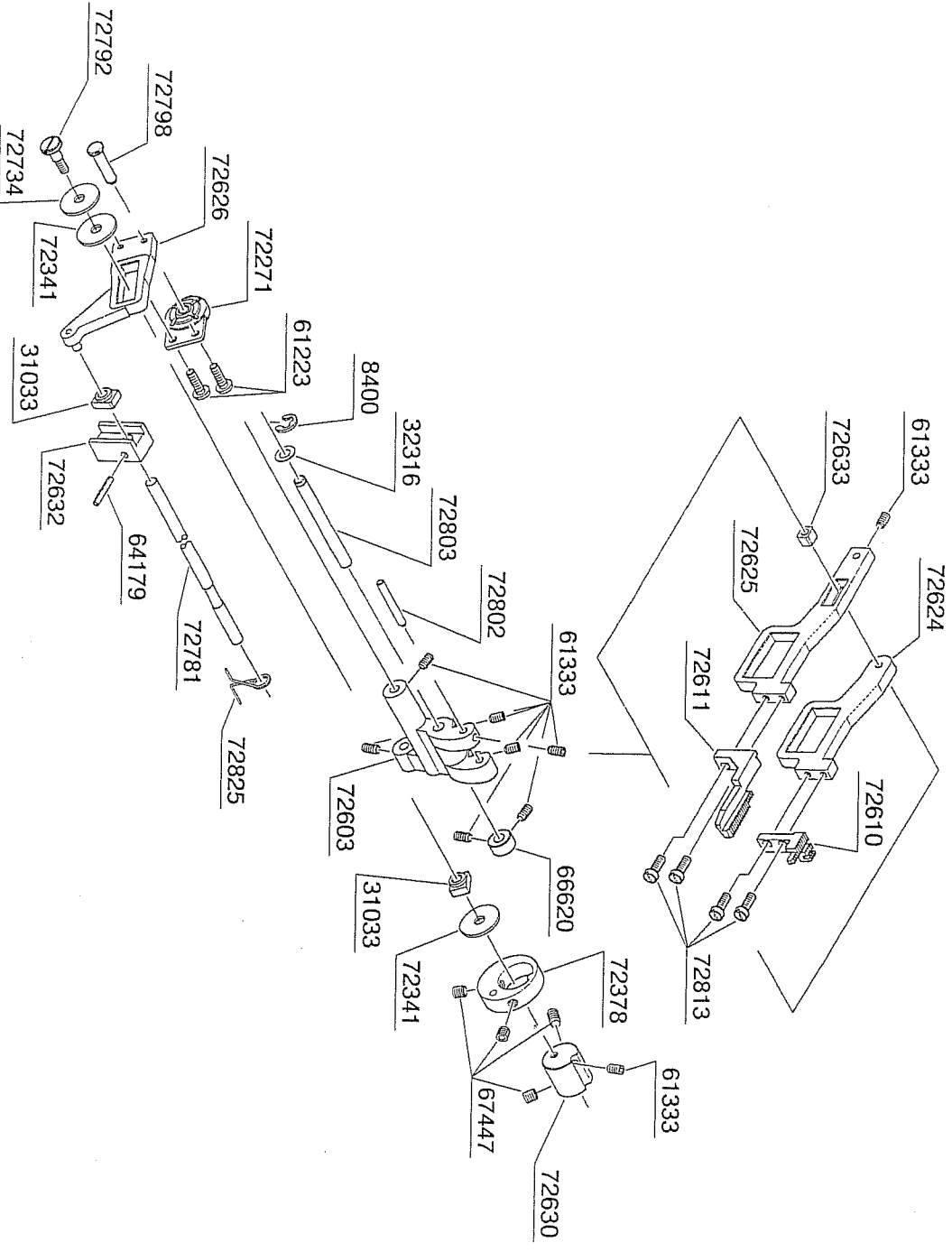

PART NO.	DESCRIPTION
8400	E5 CLIP-ON-WASHER
31033	SLIDE BLOCK
32316	WASHER
61223	M4 PHILLIPS SCREW
61333	M4 SCREW
64179	SPRING PIN
66620	COLLAR
67447	M5 SCREW
72271	BALL JOINT
72341	THRUST WASHER
72378	BALANCE WEIGHT
72603	FEED ARM
72610	REAR FEED DOG
72611	FRONT FEED DOG
72624	FEED BASE
72625	D. F. FEED BASE
72626	FEED REGULATING ARM
72630	ECCENTRIC CAM
72632	FEED REGULATING BLOCK
72633	SLIDE BLOCK
72734	WASHER
72781	SHAFT
72792	PIN
72798	PIN
72802	SHAFT
72803	SHAFT
72813	M3.5 SCREW
72825	TORSION SPRING

BUYER'S MODEL NO.	087 DW	SECTION	PAGE	REVISION	REMARKS
BUYER'S MODEL NAME	EPOCHLOCK • 087DW		3		
FACTORY MODEL	087E0 • 087R0				
ORIGINAL ISSUE	July, 1995	SERIAL NO.			

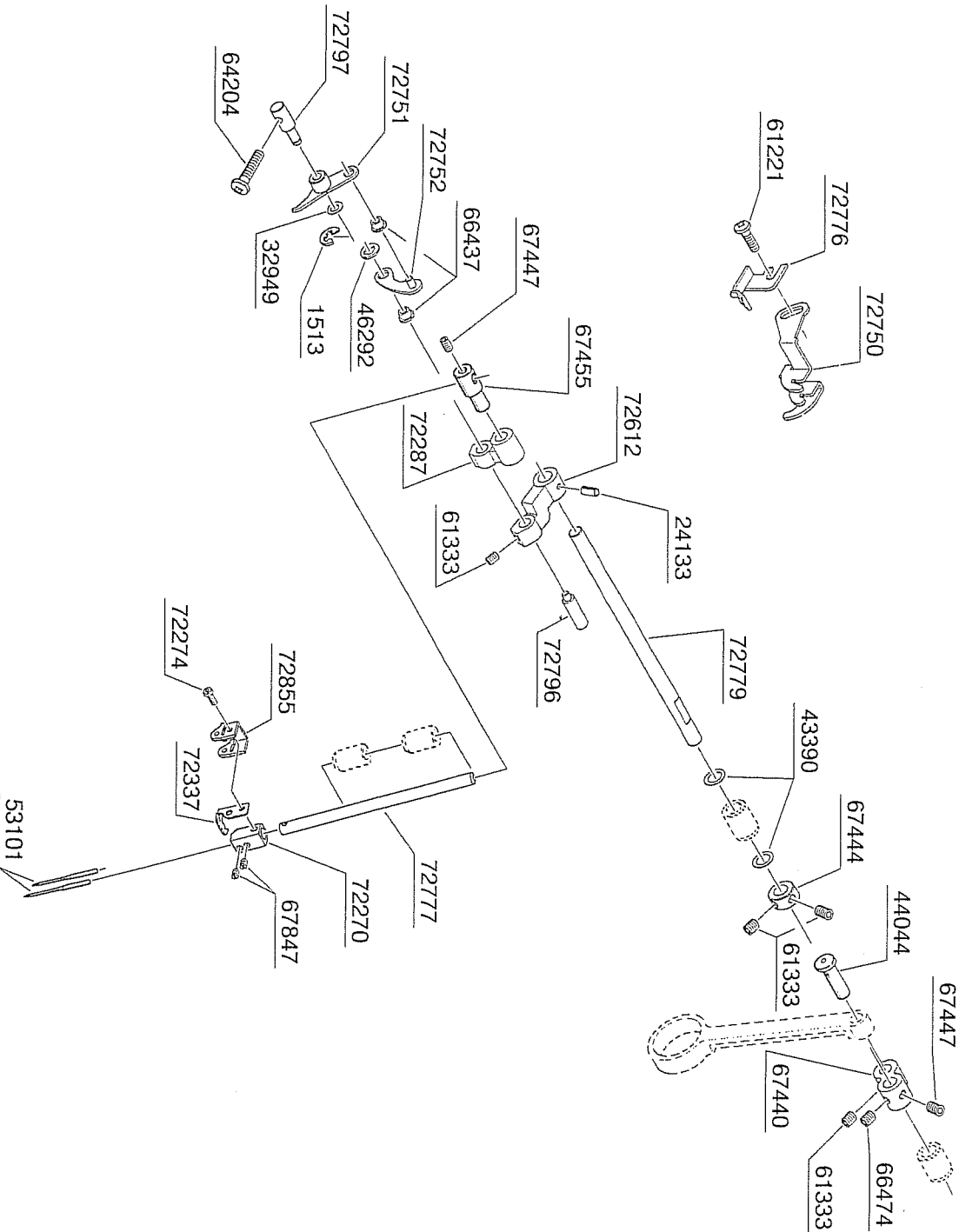

PART NO.	DESCRIPTION
1513	E4 CLIP-ON-WASHER
24133	PIPE KNOCK PIN
32949	WASHER
43390	THRUST WASHER
44044	STUD
46292	CLIP-ON-WASHER
53101	NEEDLE
61221	M4 PHILIPS SCREW
61333	M4 SCREW
64204	M4 PHILIPS SCREW
66437	BUSH
66474	M5 SCREW
67440	CRANK-ROD ARM
67444	COLLAR
67447	M5 SCREW
67455	HOLDER
67847	#7 SCREW
72270	NEEDLE CLAMP
72274	M3 SCREW
72287	NEEDLE BAR CRANK
72337	THREAD GUIDE
72612	MAIN SHAFT ARM LEVER
72750	THREAD GUIDE
72751	OSCILLATING LEVER
72752	CONNECTING ARM
72776	THREAD GUIDE
72777	NEEDLE BAR
72779	UPPER SHAFT
72796	PIN
72797	CENTER PIN
72855	THREADER POSITIONER

BUYER'S MODEL NO.	087 DW	SECTION		PAGE	4	REVISION		REMARKS		PART NO.	DESCRIPTION
BUYER'S MODEL NAME	EPOCHLOCK • 087DW									1513	E4 CLIP-ON-WASHER
FACTORY MODEL	087E0 • 087R0									8400	E5 CLIP-ON-WASHER
ORIGINAL ISSUE	July, 1995	SERIAL NO.								32316	WASHER
										58220	WASHER
										61221	M4 PHILLIPS SCREW

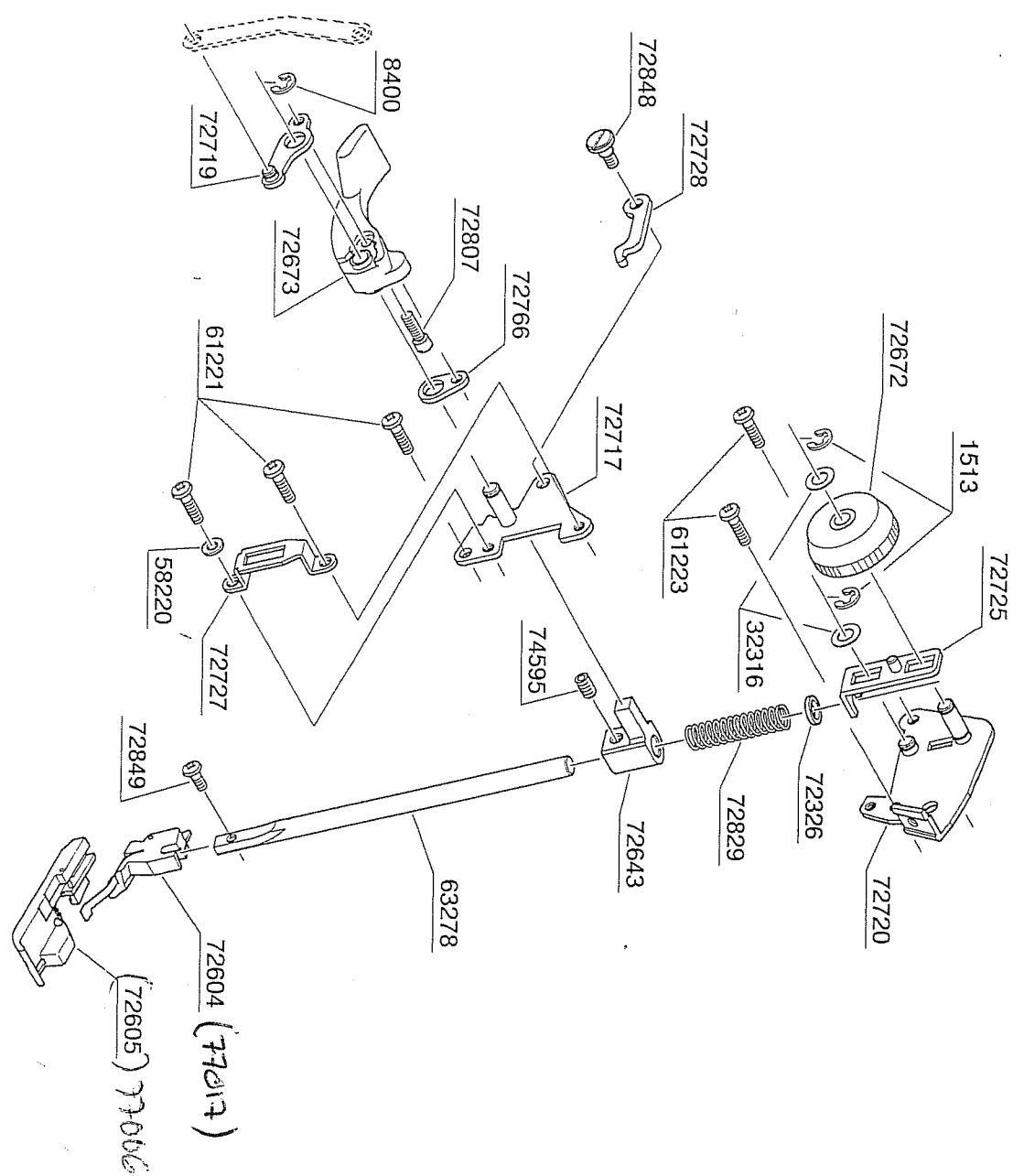

72807	M4 STUD SCREW
72829	COMPRESSION SPRING
72848	#4 STUD SCREW
72849	#7 PHILLIPS SCREW
74595	M5 SCREW
72720	BRACKET
72725	GUIDE PLATE
72727	GUIDE PLATE
72728	TENSION RELEASE LEVER
72766	LIFTER
72643	PRESSER BAR GUIDE BLOCK
72672	PRESSER CONTROL KNOB
72673	PRESSER FOOT RIFTLING LEVER
72717	BRACKET
72719	TENSION RELEASE ARM
61223	M4 PHILLIPS SCREW
63278	PRESSER BAR
72326	WASHER
72604	PRESSER FOOT HOLDER
72605	PRESSER FOOT

BUYER'S MODEL NO.	087 DW	SECTION	PAGE	REVISION	REMARKS
BUYER'S MODEL NAME	EPOCHLOCK • 087DW		5		
FACTORY MODEL	087E0 • 087R0				
ORIGINAL ISSUE	July, 1995	SERIAL NO.			

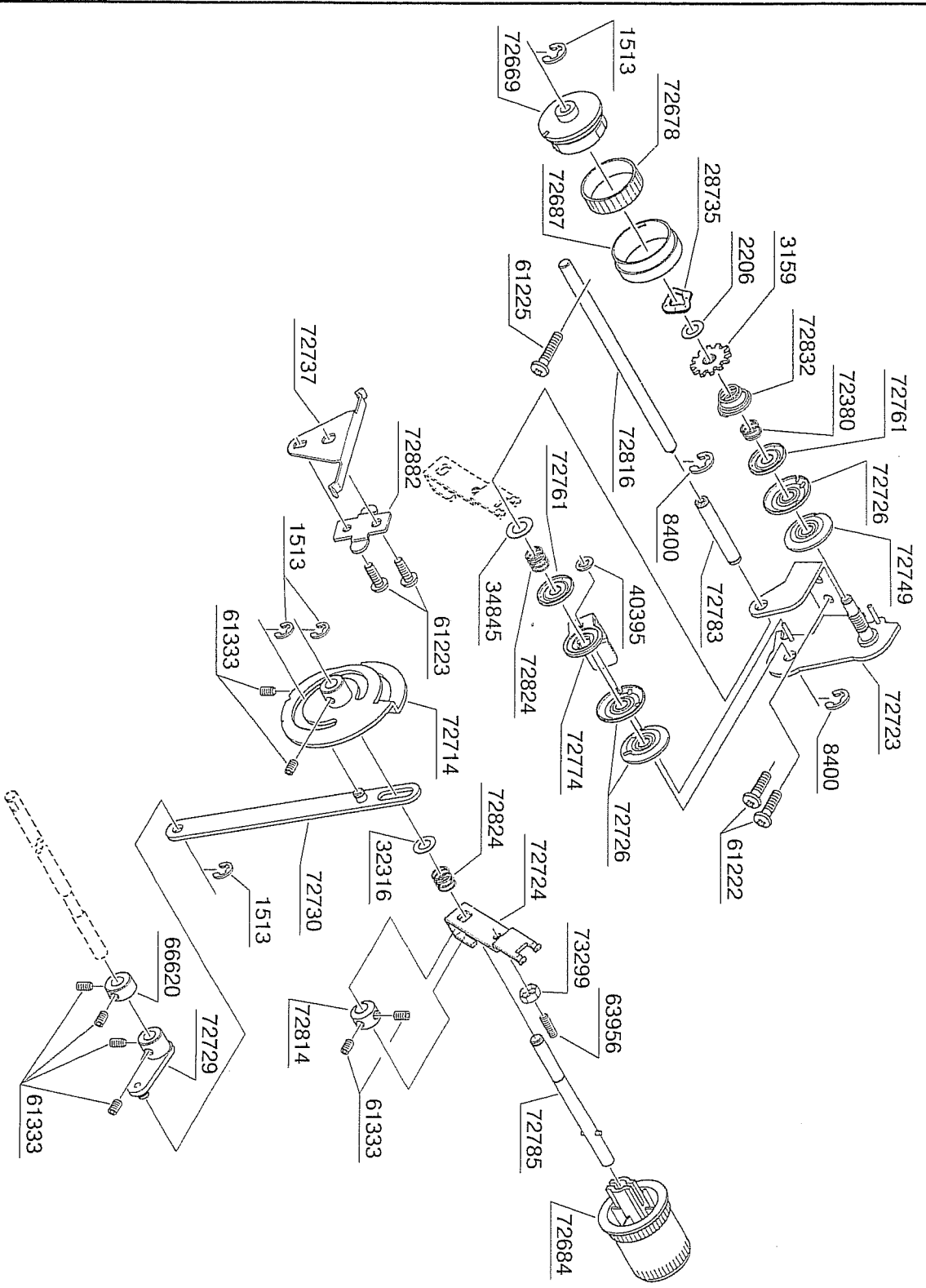

PART NO.	DESCRIPTION
1513	E4 CLIP-ON-WASHER
2206	WASHER
3159	TOOTHED WASHER
8400	E5 CLIP-ON-WASHER
28735	CRINKLE WASHER
32316	WASHER
34845	WASHER
40395	CLIP-ON-WASHER
61222	M4 PHILLIPS SCREW
61223	M4 PHILLIPS SCREW
61225	M4 PHILLIPS SCREW
61333	M4 SCREW
63956	M4 SCREW
66620	COLLAR
72380	COMPRESSION SPRING
72669	THREAD TENSION DIAL
72678	RUBBER
72684	STITCH LENGTH CONTROL DIAL
72687	THREAD TENSION RING
72714	STITCH LENGTH CONTROL CAM
72723	BRACKET
72724	TENSION DISC PRESSURE
72726	DIAL TENSION DISC (B)
72729	STITCH LENGTH CONTROL ARM
72730	CONNECTING PLATE
72737	LEAF SPRING
72749	DIAL TENSION DISC (A)
72761	PRESSER DISC
72774	PRESSER PLATE
72783	SHAFT
72785	SHAFT
72814	COLLAR
72816	SHAFT
72824	COMPRESSION SPRING
72832	COMPRESSION SPRING
72882	STOPPER
73299	M4 TORQUE NUT

BUYER'S MODEL NO.	087 DW	SECTION	PAGE	REVISION	REMARKS
BUYER'S MODEL NAME	EPOCHLOCK • 087DW	—	6		
FACTORY MODEL	087E0 • 087R0				
ORIGINAL ISSUE	July, 1995	SERIAL NO.			

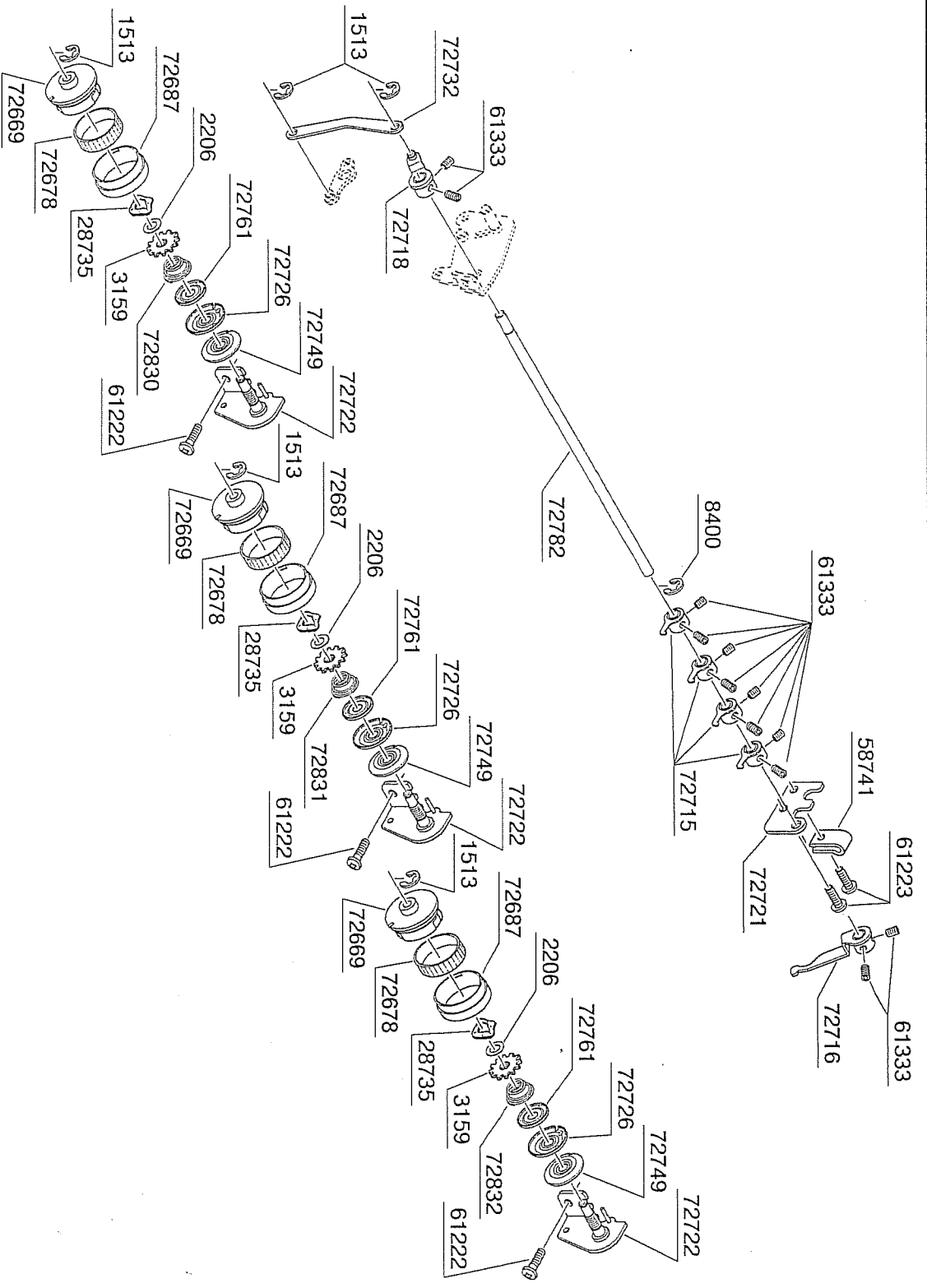

PART NO.	DESCRIPTION
1513	E4 CLIP-ON-WASHER
2206	WASHER
3159	TOOTHED WASHER
8400	E5 CLIP-ON-WASHER
28735	CRINKLE WASHER
58741	CORD GUARD
61222	M4 PHILLIPS SCREW
61223	M4 PHILLIPS SCREW
61333	M4 SCREW
72669	THREAD TENSION DIAL
72678	RUBBER
72687	THREAD TENSION RING
72715	TENSION RELEASE PLATE (A)
72716	TENSION RELEASE PLATE (B)
72718	TENSION RELEASE ARM
72721	TENSION RELEASE GUIDE
72722	BRACKET
72726	DIAL TENSION DISC (B)
72732	TENSION RELEASE LINK
72749	DIAL TENSION DISC (A)
72761	PRESSER DISC
72782	SHAFT
72830	COMPRESSION SPRING
72831	COMPRESSION SPRING
72832	COMPRESSION SPRING

BUYER'S MODEL NO.	087 DW	SECTION	PAGE	REVISION	REMARKS
BUYER'S MODEL NAME	EPOCHLOCK • 087 DW		8		
FACTORY MODEL	087E0 • 087R0				
ORIGINAL ISSUE	July, 1995	SERIAL NO.			

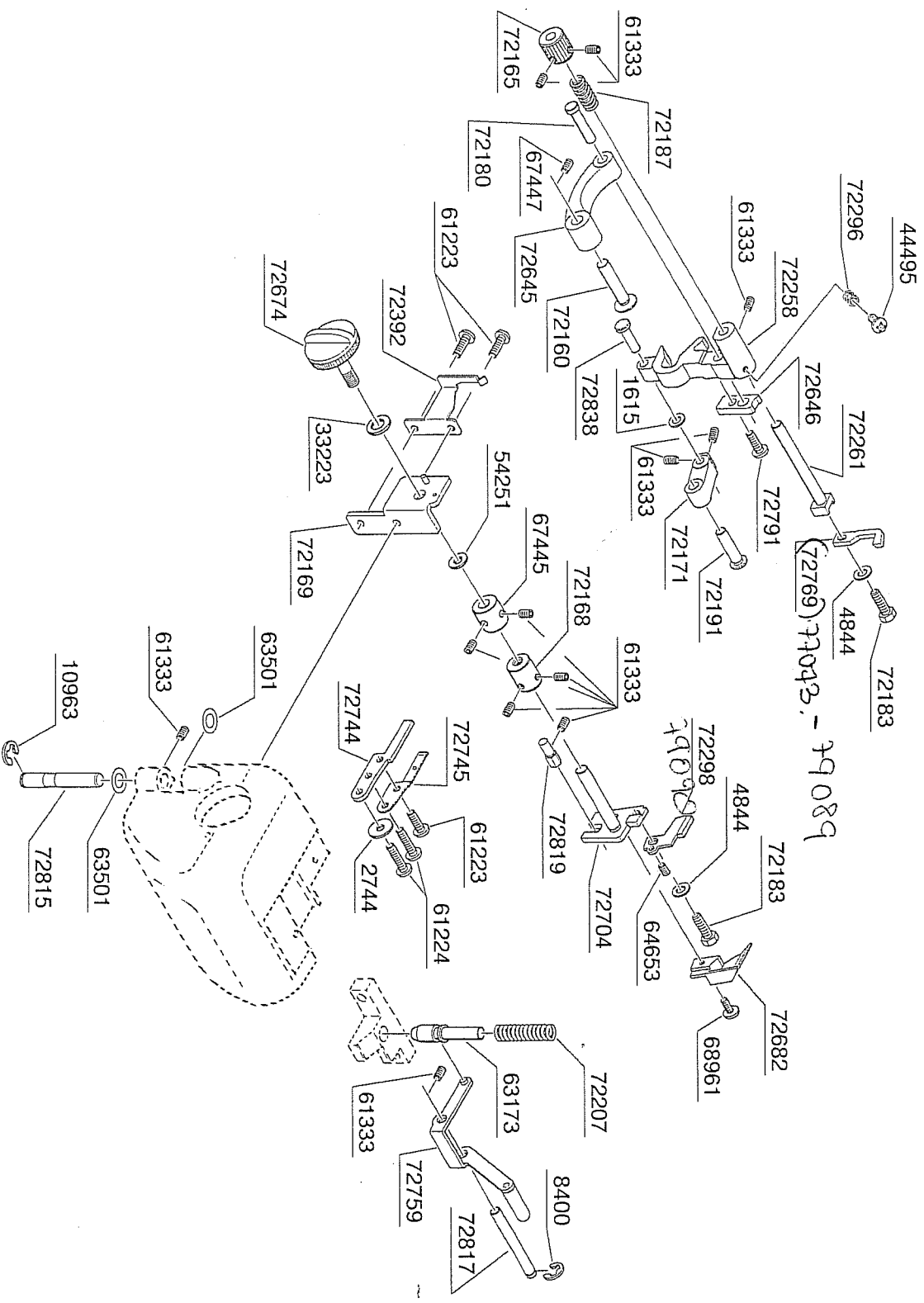

PART NO.	DESCRIPTION
1615	WASHER
2744	WASHER
4844	WASHER
8400	E5 CLIP-ON-WASHER
10963	E6 CLIP-ON-WASHER
33223	WASHER
44495	M3 PHILIPS SCREW
54251	THRUST WASHER
61223	M4 PHILIPS SCREW
61224	M4 PHILIPS SCREW
61333	M4 SCREW
63173	PIN
63501	WASHER
64653	M3 SCREW
67445	COLLAR
67447	M5 SCREW
68961	M3 PHILIPS SCREW
72160	STUD
72165	KNIFE RELEASE KNOB
72168	COLLAR
72169	KNOB MOUNTING BRACKET
72171	LINK (B)
72180	STUD
72183	M3 x 5 BOLT
72187	COMPRESSION SPRING
72191	STUD
72207	COMPRESSION SPRING
72258	DRIVING ARM
72261	SHAFT
72296	COMPRESSION SPRING
72298	LOWER KNIFE SPRING PLATE
72392	LINK
72645	POSITIONER CONTROL KNOB
72654	LOWER KNIFE COVER
72682	LOWER KNIFE HOLDER
72704	NEEDLE PLATE HOLDER
72744	LEAF SPRING
72745	LEAF SPRING
72759	LEVER
72769	UPPER KNIFE
72791	M4 SCREW
72815	SHAFT
72817	SHAFT
72819	HEXAGONAL PIN
72838	STUD

BUYER'S MODEL NO.	087 DW	SECTION		PAGE	9	REVISION		REMARKS	
BUYER'S MODEL NAME	EPOCHLOCK • 087DW								
FACTORY MODEL	087E0 • 087R0								
ORIGINAL ISSUE	July, 1995	SERIAL NO.							

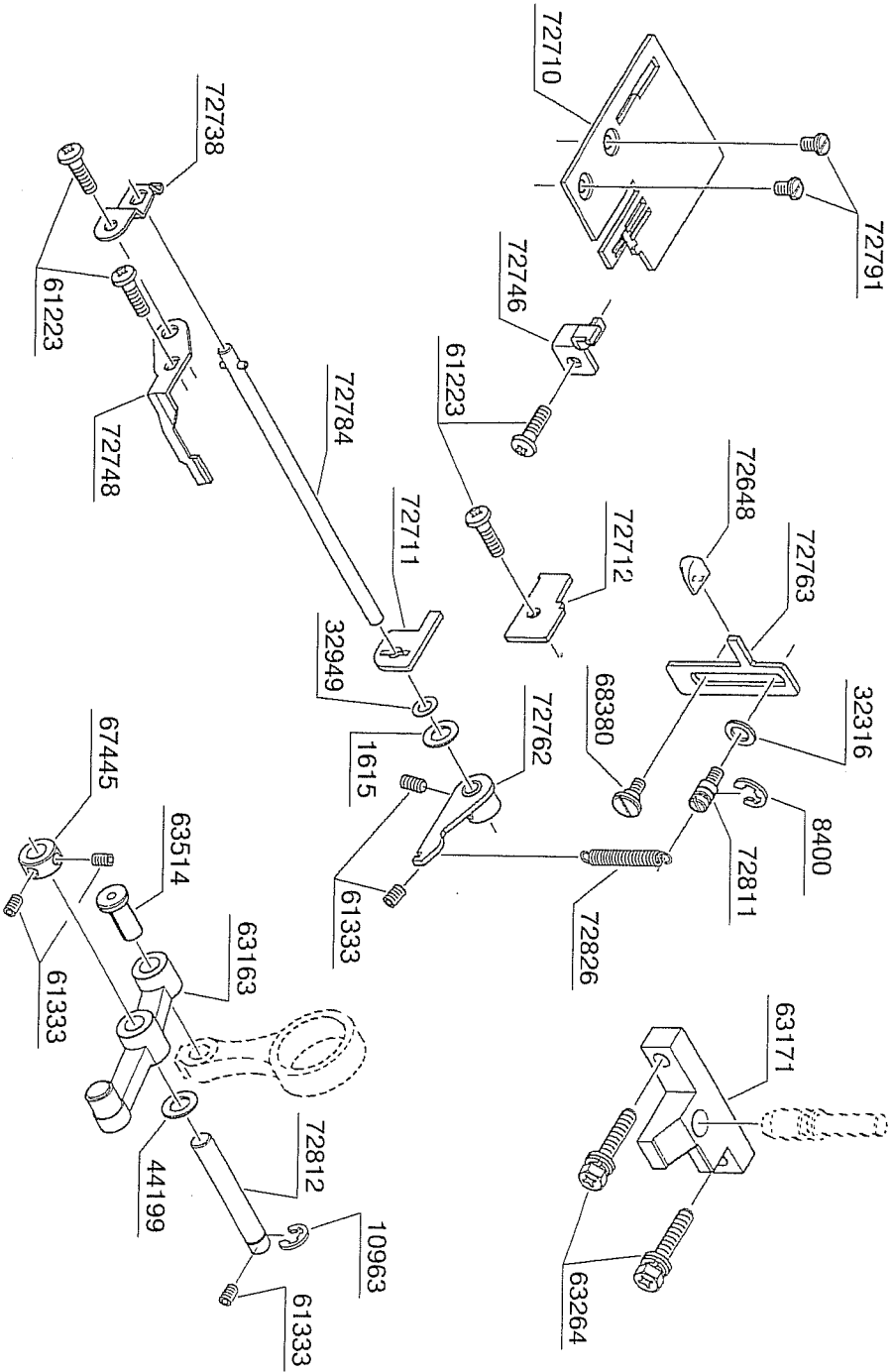

PART NO.	DESCRIPTION
1615	WASHER
8400	E5 CLIP-ON-WASHER
10963	E6 CLIP-ON-WASHER
32316	WASHER
32949	WASHER
44199	WASHER
61223	M4 PHILLIPS SCREW
61333	M4 SCREW
63163	KNIFE LEVER ASSEMBLY
63171	FIXING BASE
63264	M5 BOLT WITH WASHER
63514	STUD
67445	COLLAR
68380	M4 STUD SCREW
72648	KNOB
72710	NEEDLE PLATE
72711	UPPER CUTTING BLADE
72712	LOWER CUTTING BLADE
72738	LEAF SPRING
72746	NEEDLE PLATE HOLDER
72748	NEEDLE RECEIVER (B)
72762	THREAD CUTTER ARM
72763	SLIDER
72784	SHAFT
72791	M4 SCREW
72811	M4 STUD SCREW
72812	SHAFT
72826	EXTENSION SPRING

BUYER'S MODEL NO.	087DW	SECTION	PAGE	REVISION	REMARKS
BUYER'S MODEL NAME	EPOCHLOCK-087DW		10		
FACTORY MODEL	087E0-087R0				
ORIGINAL ISSUE	July, 1995	SERIAL NO.			

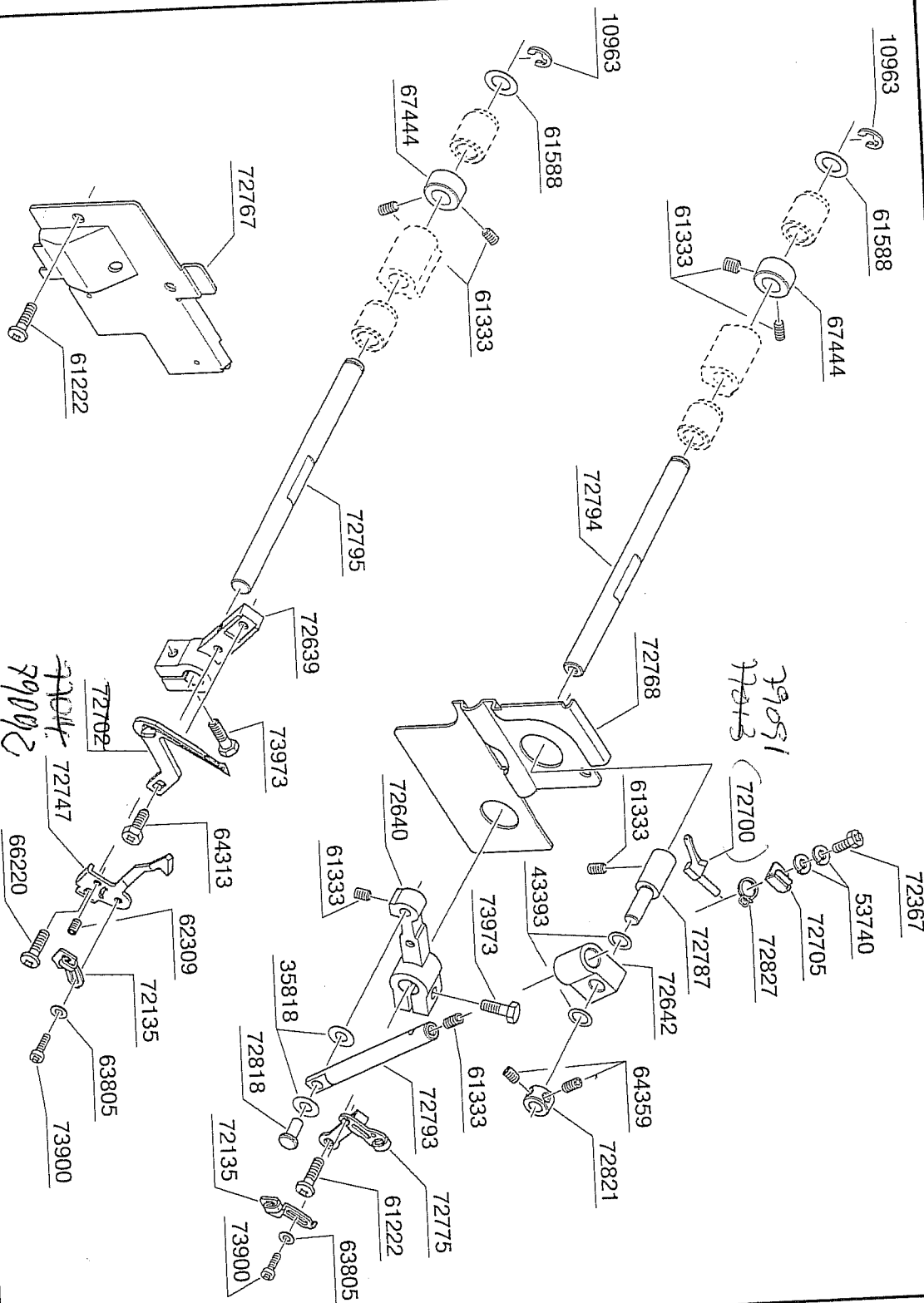

PART NO.	DESCRIPTION
10963	E6 CLIP-ON-WASHER
35818	WASHER
43393	WASHER
53740	SPRING WASHER
61222	M4 PHILIPS SCREW
61333	M4 SCREW
61588	WASHER
62309	M3 SCREW
63805	WASHER
64313	M4 BOLT
64359	M4 SCREW
66220	M3.5 PHILIPS SCREW
67444	COLLAR
72135	THREAD GUIDE (B)
72367	M4 BOLT
72639	LOOPER BASE
72640	UPPER LOOPER SUPPORTING ARM
72642	PIVOT
72700	UPPER LOOPER
72702	LOWER LOOPER
72705	SUPPORT PLATE
72717	NEEDLE RECEIVER (A)
72767	BED COVER
72768	LOOPER COVER
72775	THREAD GUIDE (A)
72787	PIN
72793	LOOPER SLIDE SHAFT
72794	SHAFT
72795	SHAFT
72818	PIN
72821	COLLAR
72827	THREAD GUIDE
73900	M3 PHILIPS SCREW
73973	M4 BOLT

BUYER'S MODEL NO.	087DW	SECTION		PAGE	11	REVISION		REMARKS	
BUYER'S MODEL NAME	EPOCHLOCK • 087DW								
FACTORY MODEL	087E0 • 087R0								
ORIGINAL ISSUE	July, 1995	SERIAL NO.							

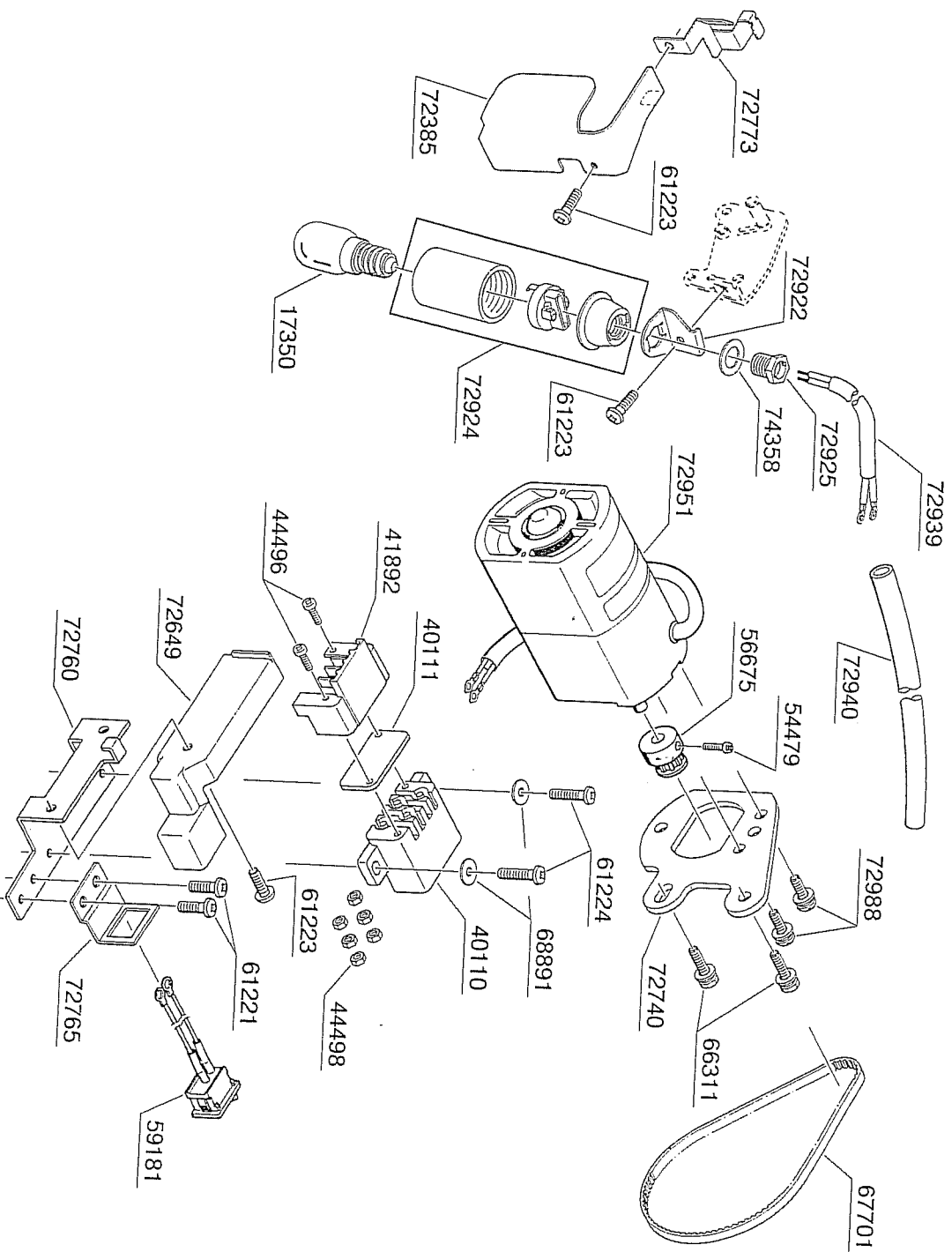

PART NO.	DESCRIPTION
17350	LIGHT BULB
40110	TERMINAL BLOCK
40111	TERMINAL BLOCK COVER
41892	TERMINAL BLOCK COVER
44496	M3 PHILIPPS SCREW
44498	M3 NUT
54479	M2.5 PHILIPPS SCREW
56675	MOTOR PULLEY
59181	SWITCH ASSEMBLY
61221	M4 PHILIPPS SCREW
61223	M4 PHILIPPS SCREW
61224	M4 PHILIPPS SCREW
66311	M5 BOLT WITH WASHER
67701	TIMING BELT
68891	WASHER
72385	REFLECTION PLATE
72649	TERMINAL CASE
72740	VINYL TUBE
72760	TERMINAL BRACKET
72785	SWITCH BRACKET
72773	CORD GUIDE
72922	LAMP HOLDER BRACKET
72924	LAMP HOLDER ASSEMBLY
72925	CAP BOLT
72939	HARNASS
72940	MOTOR BRACKET
72951	MOTOR
72988	M4 PHILIPPS SCREW WITH WASHER
74358	WASHER

BUYER'S MODEL NO.	087 DW	SECTION		PAGE	12	REVISION		REMARKS	
BUYER'S MODEL NAME	EPOCHLOCK • 087DW								
FACTORY MODEL	087E0 • 087R0								
ORIGINAL ISSUE	July, 1995	SERIAL NO.							

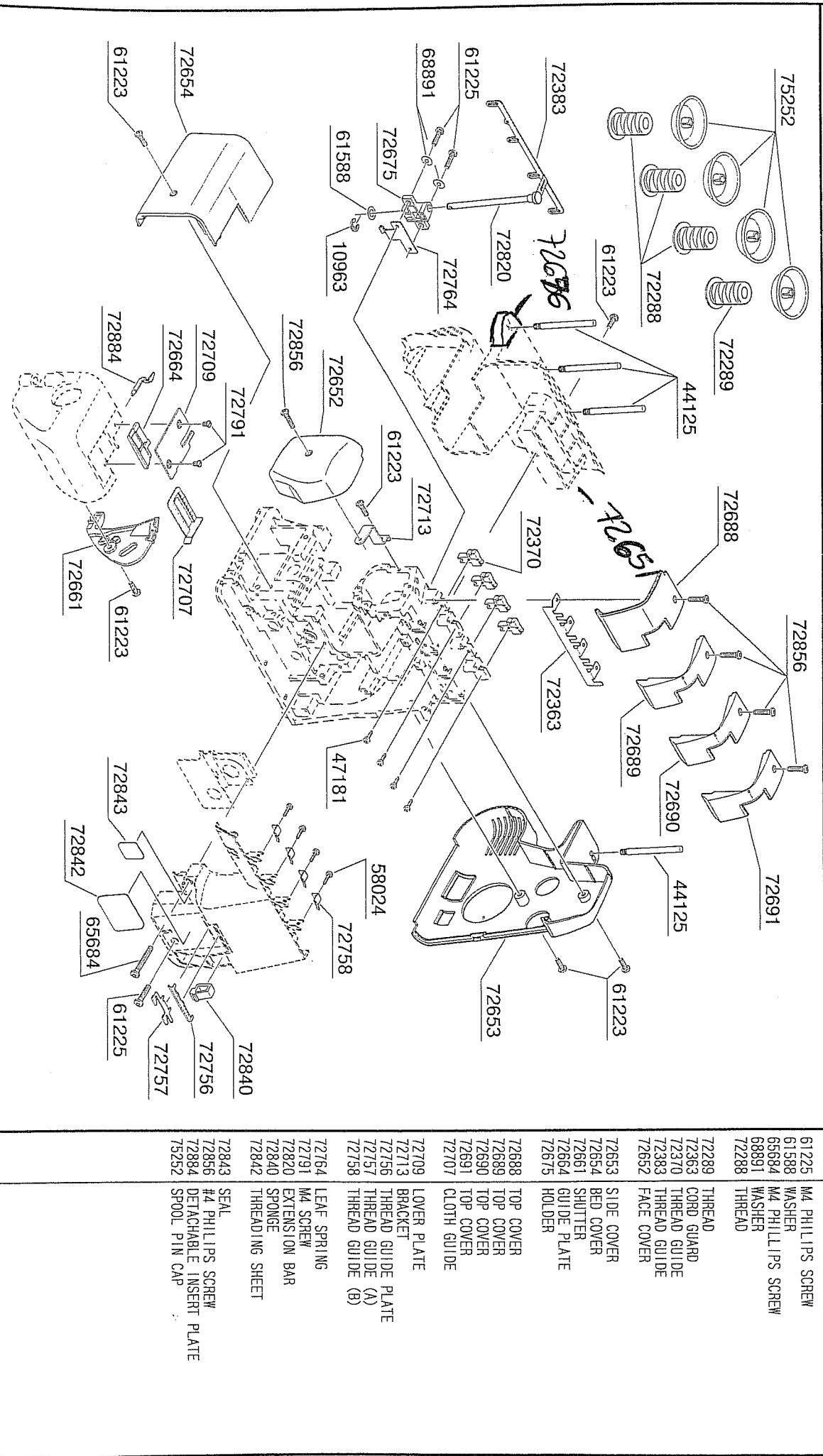

PART NO.	DESCRIPTION
10963	E6 CLIP-ON-WASHER
44125	SPOOL PIN
47181	TAPPING SCREW
58024	TAPPING SCREW
61223	M4 PHILLIPS SCREW
61225	M4 PHILLIPS SCREW
61588	WASHER
65684	M4 PHILLIPS SCREW
68891	WASHER
72288	THREAD
72289	THREAD
72363	CORD GUARD
72370	THREAD GUIDE
72383	THREAD GUIDE
72652	FACE COVER
72653	SIDE COVER
72654	BED COVER
72661	SHUTTER
72664	GUIDE PLATE
72675	HOLDER
72688	TOP COVER
72689	TOP COVER
72690	TOP COVER
72707	TOP COVER
72709	LOWER PLATE
72713	BRACKET
72756	THREAD GUIDE PLATE
72757	THREAD GUIDE (A)
72758	THREAD GUIDE (B)
72764	LEAF SPRING
72791	M4 SCREW
72820	EXTENSION BAR
72840	SPONGE
72842	THREADING SHEET
72843	SEAL
72856	#4 PHILLIPS SCREW
72884	DETACHABLE INSERT PLATE
75252	SPOOL PIN CAP

BUYER'S MODEL NO.	087 DW	SECTION		PAGE	13	REVISION		REMARKS	
BUYER'S MODEL NAME	EPOCHLOCK • 087DW								
FACTORY MODEL	087E0 • 087R0								
ORIGINAL ISSUE	July, 1995	SERIAL NO.							

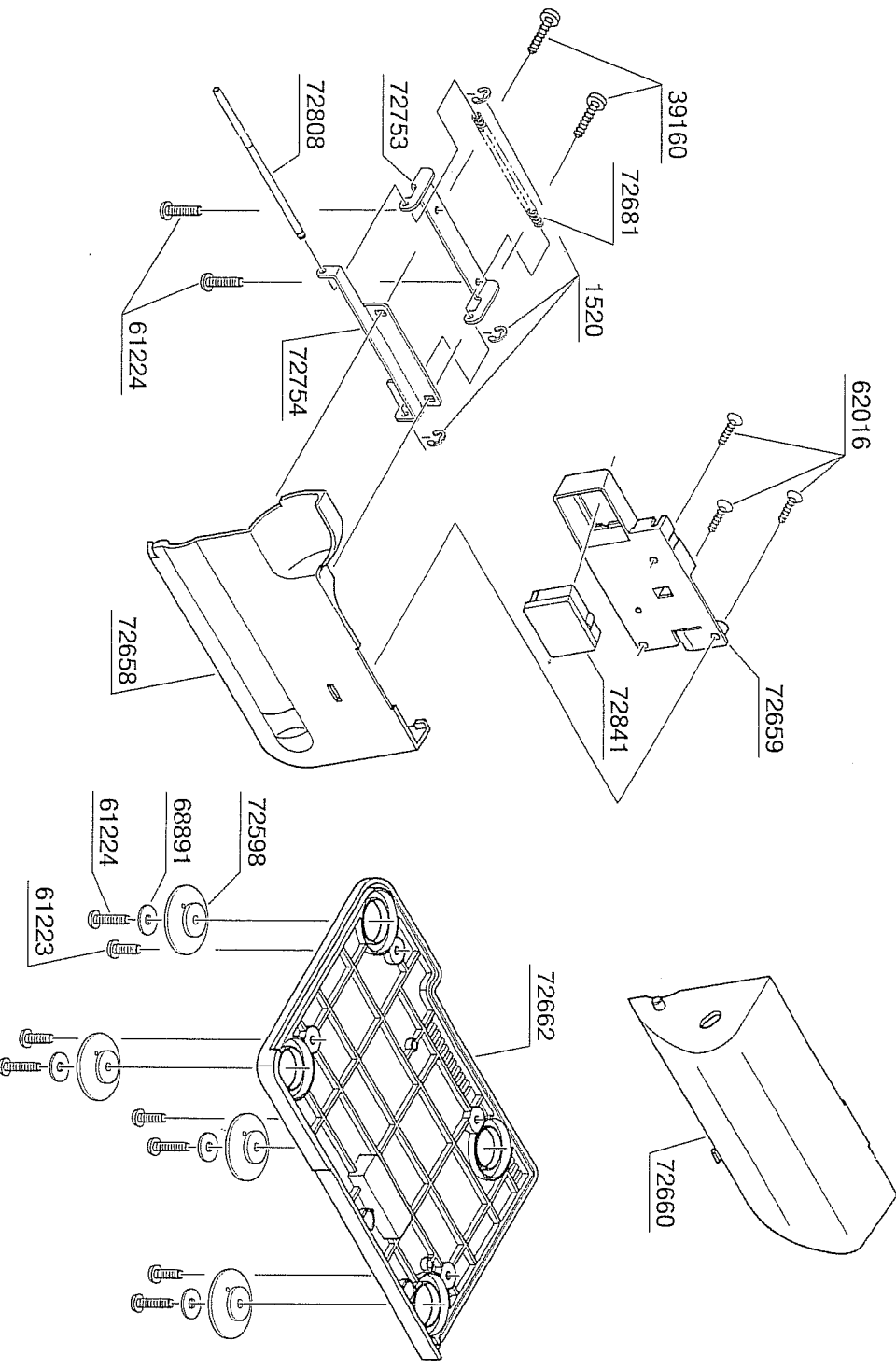

PART NO.	DESCRIPTION
1520	E3 CLIP-ON-WASHER
39160	TAPPING SCREW
61223	M4 PHILIPS SCREW
61224	M4 PHILIPS SCREW
62016	TAPPING SCREW
68891	WASHER
72598	RUBBER CUSHION
72658	FRONT COVER
72659	INNER ATTACHMENT CASE
72660	LINT BOX
72662	BASE
72681	COMPRESSION SPRING
72753	HINGED BRACKET (A)
72754	HINGED BRACKET (B)
72808	SHAFT
72841	SPONGE HOLDER