

REFER TO IMPORTANT NOTICE BELOW

PARTS LIST FOR

Model 314 (after 383),

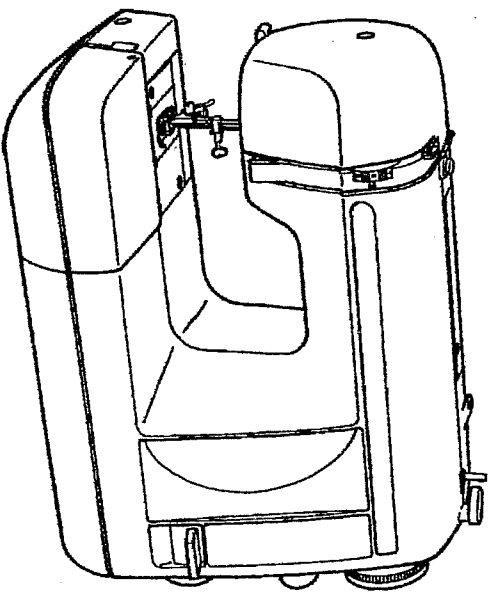

JAGUAR®

IMPORTANT:

WHEN ORDERING THE PARTS ALWAYS CHECK THE SERIAL NUMBER OF THE MACHINE.

FIRST DIGIT (3) OF THE SERIAL NUMBER CORRESPONDS TO LAST DIGIT (D) OF THE FACTORY MODEL ABOVE.

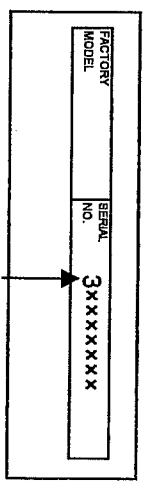

BUYER'S MODEL NO.	314	SECTION		PAGE	1	REVISION	
BUYER'S MODEL NAME							
FACTORY MODEL	CE313ED						
ORIGINAL ISSUE	September, 2002	SERIAL NO.					

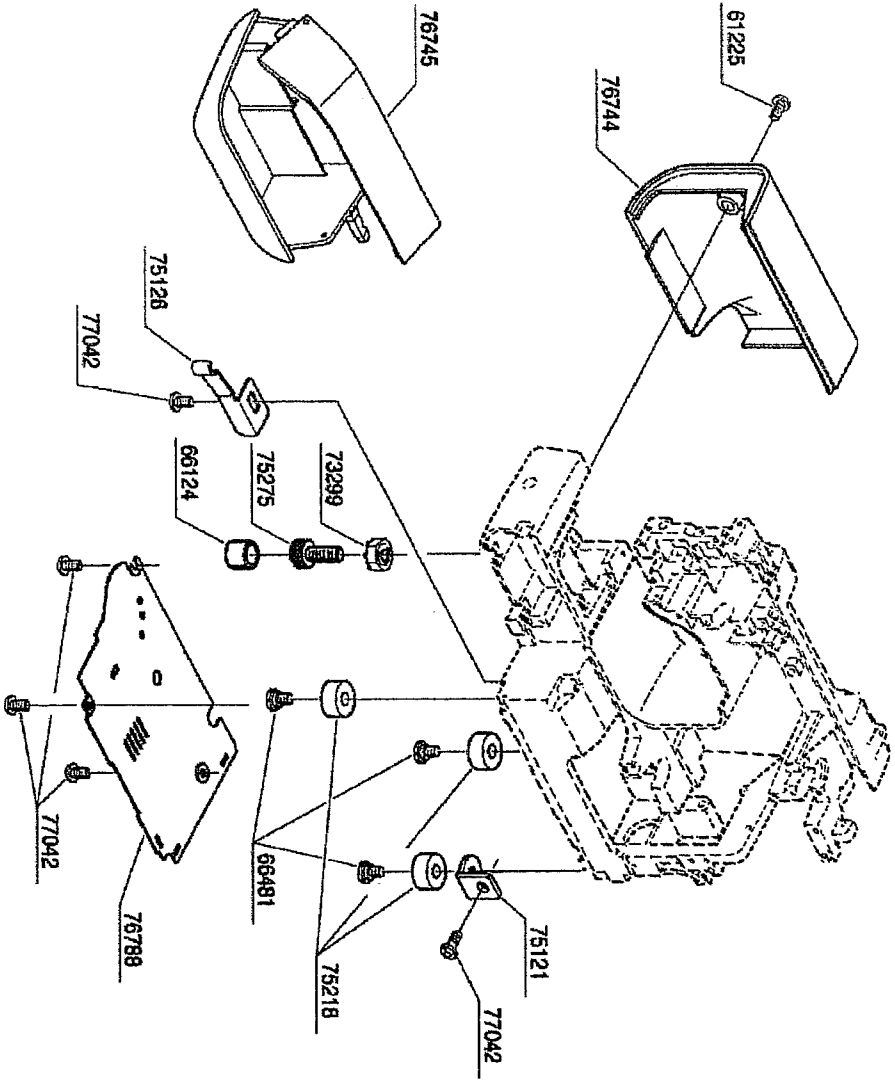

PART NO.	DESCRIPTION	REMARKS
61225	M4 PHILLIPS SCREW	
66124	RUBBER FOOT	
66481	M4 STUD SCREW	
73299	M4 TORQUE NUT	
75121	PLATE	
75126	LEAF SPRING	
75218	RUBBER CUSHION	
75275	M4 STUD SCREW	
76121	COVER	
76744	ACCESSORY BOX COMPLETE	
76789	BED COVER	
77042	M4 PHILLIPS SCREW	

BUYER'S MODEL NO.	314	SECTION	-	PAGE	2	REVISION		REMARKS
BUYER'S MODEL NAME								
FACTORY MODEL	CE313ED							
ORIGINAL ISSUE	September 2002	SERIAL NO.						

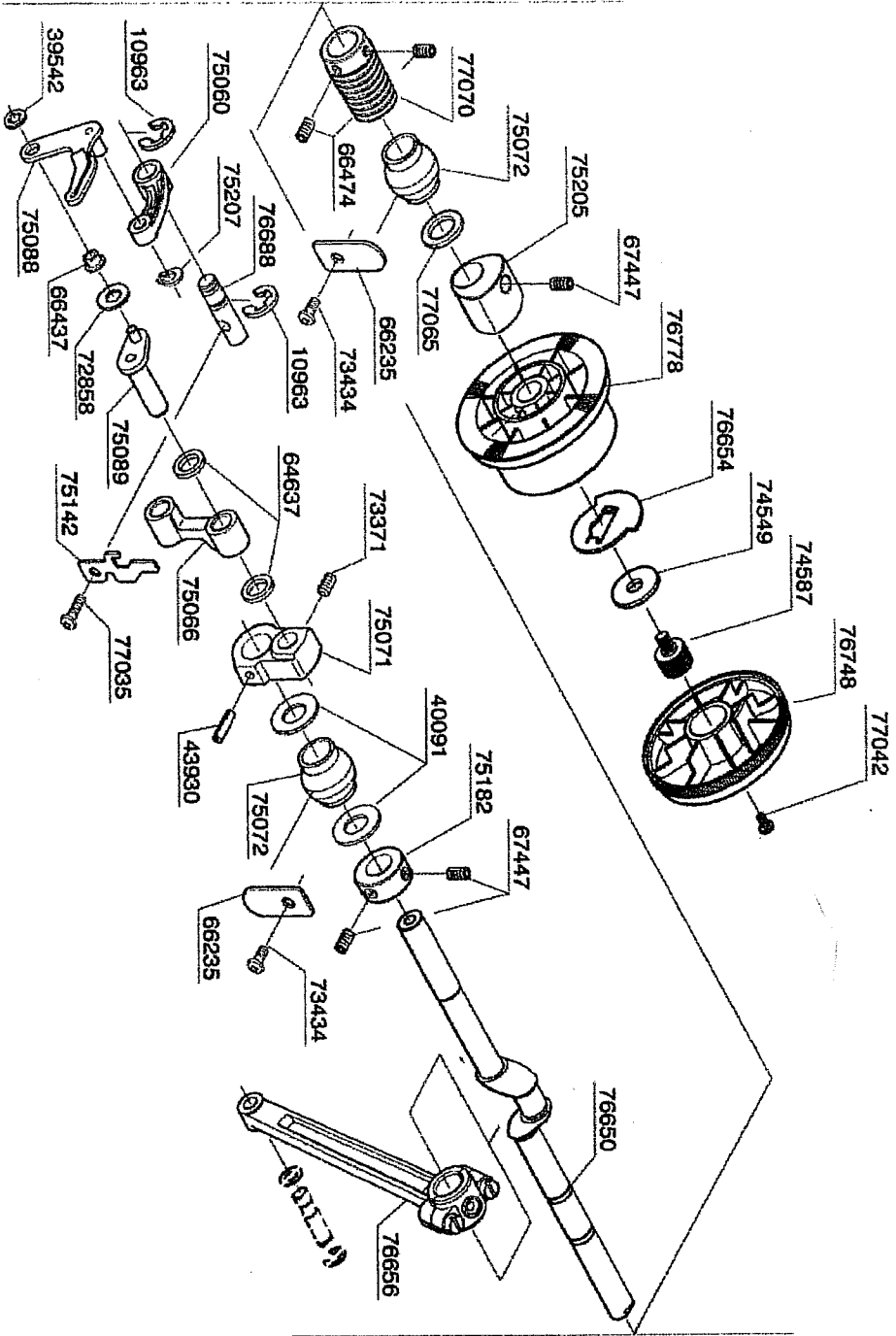

PART NO.	DESCRIPTION
10963	E6 CLIP-ON-WASHER
39542	CLIP-ON-WASHER
40091	THRUST WASHER
43930	SPRING PIN
64204	M4 PHILLIPS SCREW
64637	THRUST WASHER
66235	SECURING PLATE
66437	BUSH
66474	M5 SCREW
67447	M5 SCREW
72858	WASHER
73371	M6 SCREW
73434	M4 PHILLIPS SCREW
74549	WASHER
74587	M6 STUD SCREW
75060	TAKE-UP LEVER CRANK
75066	NEEDLE BAR CRANK
75071	BALANCE CAM
75072	BALL BUSHING
75088	TAKE-UP LEVER
75089	CRANK SHAFT
75142	CORD GUIDE
75182	COLLAR
75205	FEED REGULATING CAM
75207	CS-CLIP
76650	MAIN SHAFT
76654	WASHER
76656	CONNECTING ROD
76688	SHAFT
76748	HAND WHEEL
76778	BELT PULLEY
77042	M4 PHILLIPS SCREW
77065	FELT
77070	SPIRAL GEAR

BUYER'S MODEL NO.	314	SECTION	PAGE	REVISION	REMARKS
BUYER'S MODEL NAME		-	3		
FACTORY MODEL	CE313ED	SERIAL NO.			
ORIGINAL ISSUE	September, 2002				

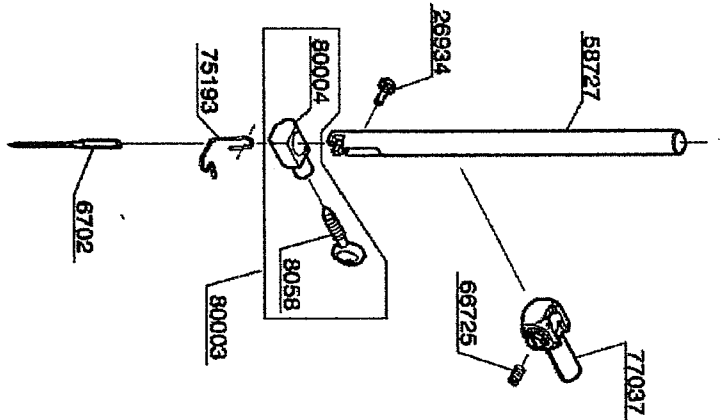
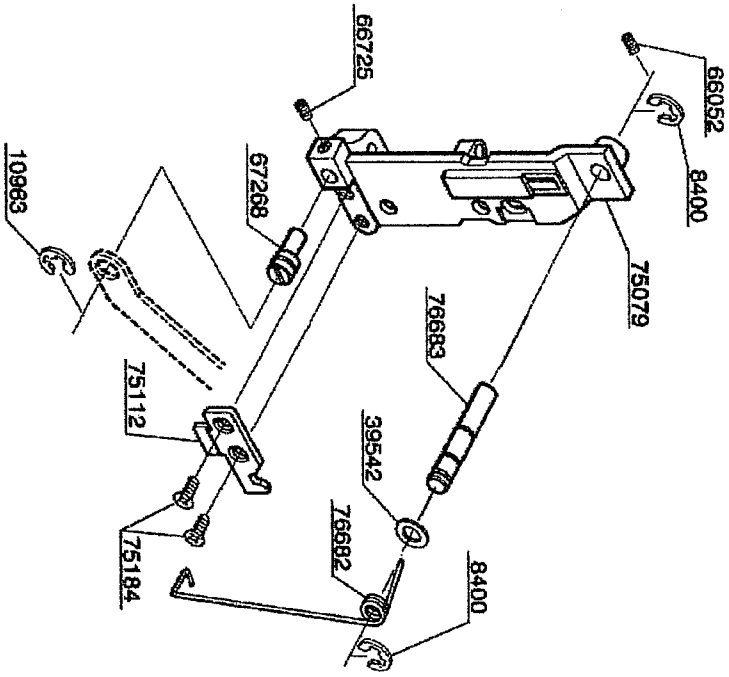

PART NO.	DESCRIPTION
6702	NEEDLE
8058	NEEDLE CLAMP SCREW
8400	E5 CLIP-ON-WASHER
10963	E6 CLIP-ON-WASHER
26934	#8 SCREW
39542	CLIP-ON-WASHER
58727	NEEDLE BAR
66052	M4 SCREW
67268	M4 SCREW
67268	ECCENTRIC PIN
75079	NEEDLE BAR SUPPORT
75112	LATCH PLATE
75184	M4 COUNTERSUNK HEAD SCREW
75193	THREAD GUIDE
76682	TORSION SPRING
76683	SHAFT
77037	NEEDLE BAR CLAMP
80003	NEEDLE CLAMP SET
80004	NEEDLE CLAMP

BUYER'S MODEL NO.	314	SECTION		REVISION		REMARKS
BUYER'S MODEL NAME						
FACTORY MODEL	CE313ED					
ORIGINAL ISSUE	September 2002	SERIAL NO.				
			4			

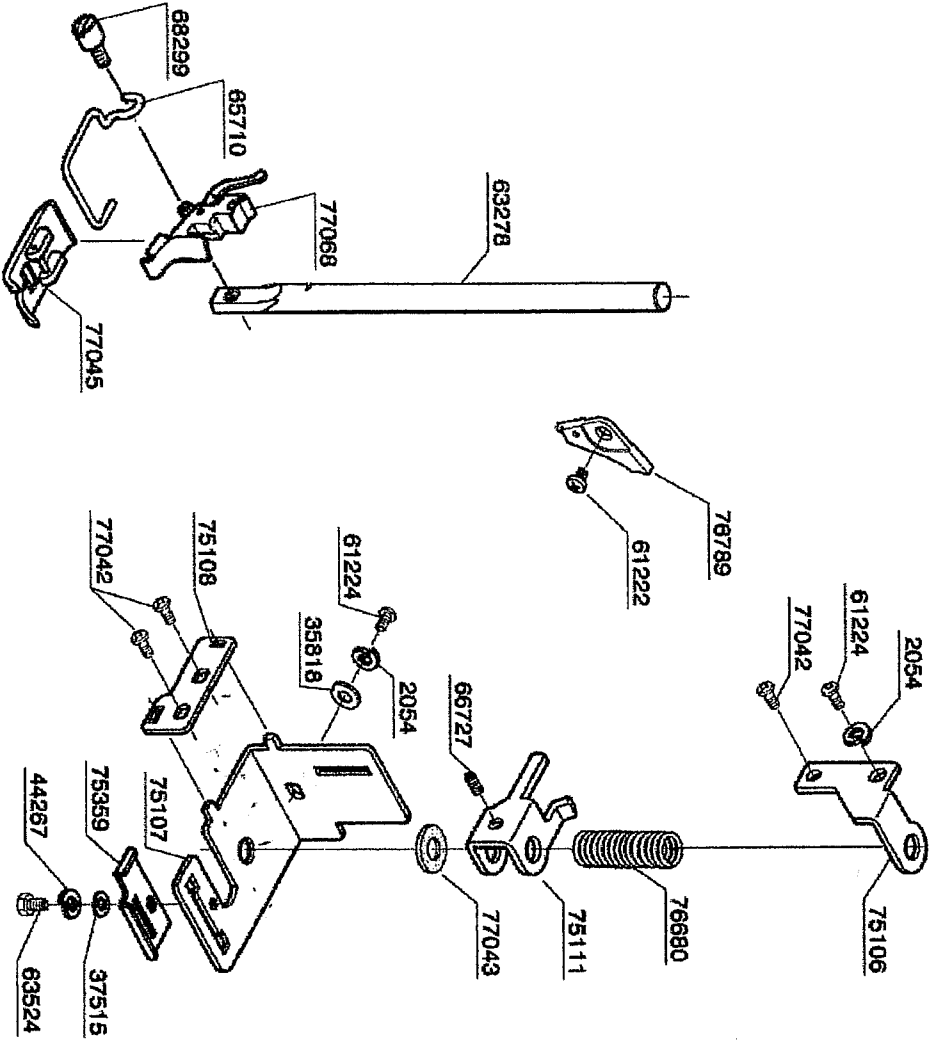

PART NO.	DESCRIPTION
2054	SPRING WASHER
35818	WASHER
37515	WASHER
44267	SPRING WASHER
61222	M4 PHILLIPS SCREW
61224	M4 PHILLIPS SCREW
63524	PRESSER BAR
63524	M3 BOLT
65710	FINGER GUARD
66727	M4 SCREW
68299	#7 SCREW FOR SHANK
75106	PRESSER BAR GUIDE
75107	BRACKET A
75108	BRACKET B
75111	PRESSER BAR GUIDE BLOCK
76680	STOPPER
76789	COMPRESSION SPRING
77042	LEVER CAP
77043	M4 PHILLIPS SCREW
77043	FELT
77045	ZIGZAG PRESSER FOOT
77068	SHANK

BUYER'S MODEL NO.	314	SECTION	PAGE	REVISION	REMARKS
BUYER'S MODEL NAME					
FACTORY MODEL	CE313ED		5		
ORIGINAL ISSUE	September, 2002	SERIAL NO.			

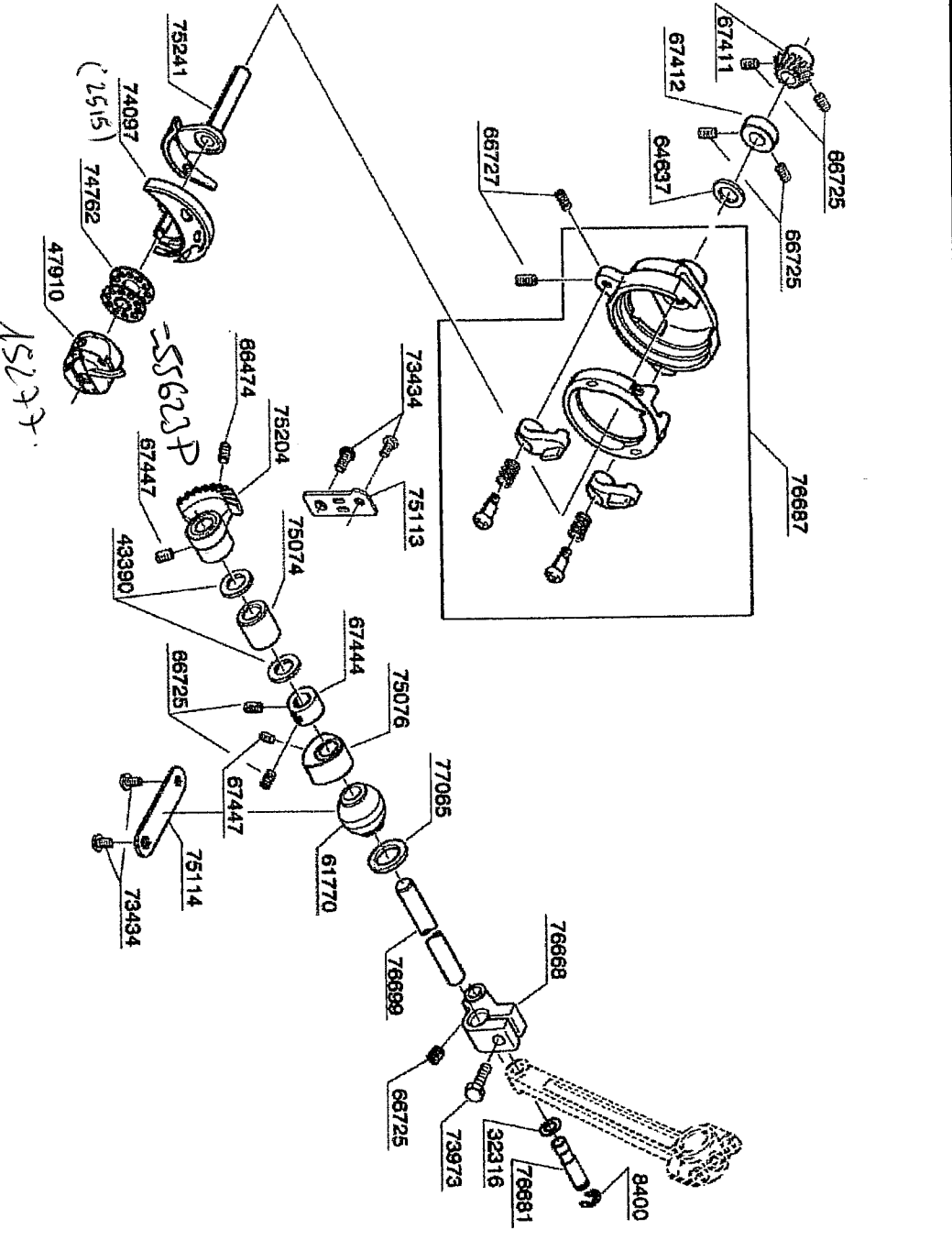

PART NO.	DESCRIPTION
8400	E5 CLIP-ON-WASHER
32316	WASHER
43390	THRUST WASHER
47910	BOBBIN CASE
61770	BALL BUSHING
64637	THRUST WASHER
66474	M5 SCREW
66725	M4 SCREW
66727	M4 SCREW
67411	SPIRAL GEAR
67412	COLLAR
67444	COLLAR
67447	M5 SCREW
73434	M4 PHILLIPS SCREW
73973	M4 BOLT
74097	SHUTTLE HOOK
74762	BOBBIN
75074	BUSHING
75076	FEED-DOG LIFTING CAM
75113	SECURING PLATE A
75114	SECURING PLATE B
75204	BEVEL GEAR
75241	SHUTTLE DRIVER
76688	LOWER SHAFT ROCKER
76681	HEADED PIN
76687	SHUTTLE RACE ASSEMBLY
76699	LOWER SHAFT
77065	FELT

BUYER'S MODEL NO.	314	SECTION	-	PAGE	6	REVISION		REMARKS	
FACTORY MODEL	CE313ED	SERIAL NO.	September 2002						
ORIGINAL ISSUE									

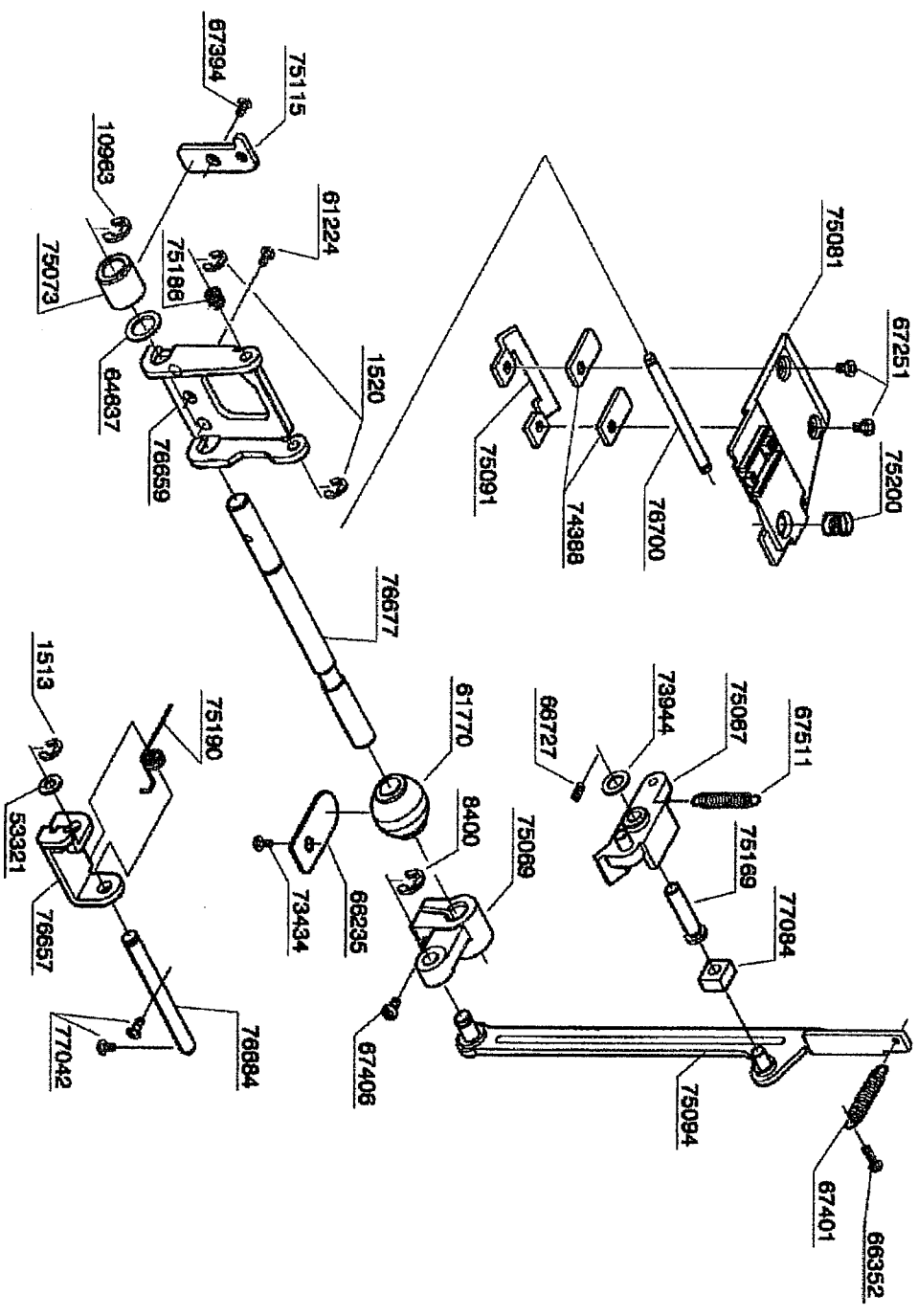

PART NO.	DESCRIPTION
1513	E4 CLIP-ON-WASHER
1520	E3 CLIP-ON-WASHER
8400	E5 CLIP-ON-WASHER
10963	E6 CLIP-ON-WASHER
53321	THRUST WASHER
61224	M4 PHILLIPS SCREW
61770	BALL BUSHING
64637	THRUST WASHER
66235	SECURING PLATE
66352	M4 PHILLIPS SCREW
66727	M4 SCREW
67251	M3.5 PHILLIPS SCREW
67394	M5 PHILLIPS SCREW
67401	EXTENSION SPRING
67511	EXTENSION SPRING
73432	M4 PHILLIPS SCREW
73944	THRUST WASHER
74388	SECURING PLATE
75067	FEED REGULATOR
75069	FEED REGULATING SHAFT ROCKER
75073	BUSHING
75081	FEED-DOG
75091	SECURING PLATE
75094	FEED REGULATING ROD
75115	SECURING PLATE C
75169	HEADED PIN
75188	COMPRESSION SPRING
75190	TORSION SPRING
75200	COMPRESSION SPRING
76657	FEED-DOG LIFTING ARM BRACKET
76639	FEED REGULATING BRACKET
76677	FEED REGULATING SHAFT
76684	SHAFT
76700	SHAFT
77035	M4 PHILLIPS SCREW
77042	M4 PHILLIPS SCREW
77094	SLIDE BLOCK

BUYER'S MODEL NO.	314	SECTION		PAGE	7	REVISION		REMARKS	
BUYER'S MODEL NAME	CE313ED								
FACTORY MODEL	September, 2002	SERIAL NO.							
ORIGINAL ISSUE									

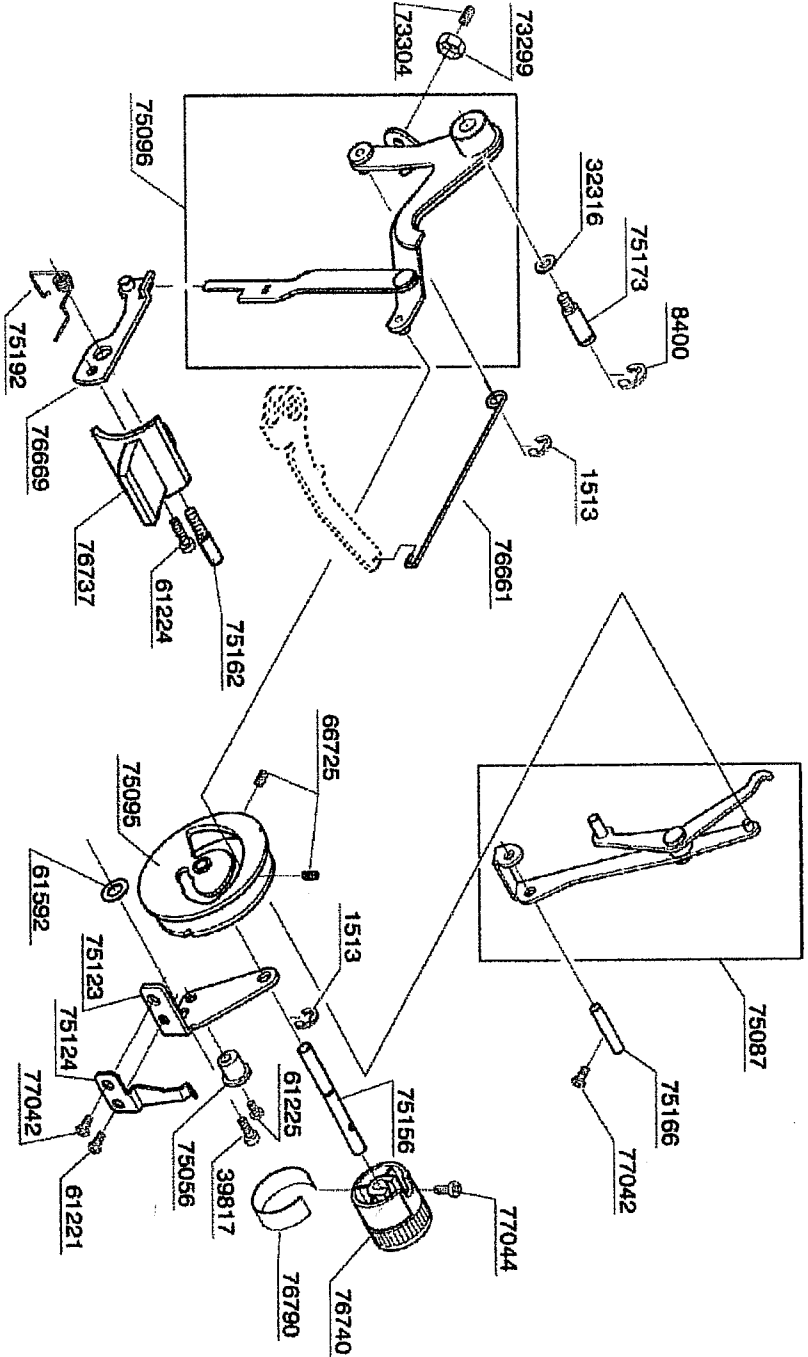

PART NO.	DESCRIPTION
1513	E4 CLIP-ON-WASHER
8400	E5 CLIP-ON-WASHER
32316	WASHER
39817	M4 PHILLIPS SCREW
61221	M4 PHILLIPS SCREW
61224	M4 PHILLIPS SCREW
61225	M4 PHILLIPS SCREW
61592	WASHER
66725	M4 SCREW
73299	M4 TORQUE NUT
73304	M4 SCREW
75056	ECCENTRIC IDLER PULLEY
75087	STRETCH STITCH CONTROL LINK ASSEMBLY
75095	STITCH LENGTH CONTROL CAM
75096	FEED CONTROL LINK ASSEMBLY
75123	CONTROL DIAL BRACKET
75124	LEAF SPRING
75156	SHAFT
75162	M4 STUD SCREW
75166	SHAFT
75173	M4 STUD SCREW
75192	TORSION SPRING
76661	BH WIRE ROD
76669	REVERSE STITCH ARM
76737	REVERSE STITCH LEVER
76740	STITCH LENGTH CONTROL DIAL
76790	SEAL
77042	M4 PHILLIPS SCREW
77044	M3 PHILLIPS SCREW

BUYER'S MODEL NO.	314	SECTION		PAGE	8	REVISION		REMARKS	
BUYER'S MODEL NAME									
FACTORY MODEL	GE313ED								
ORIGINAL ISSUE	September, 2002	SERIAL NO.							

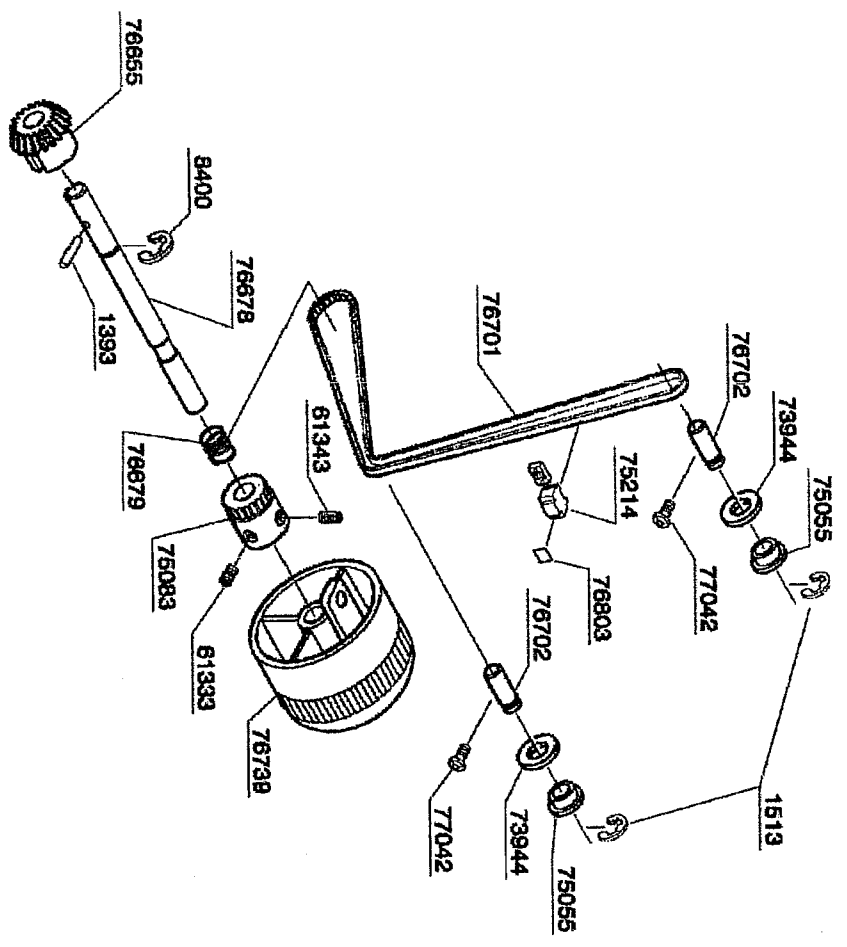

PART NO.	DESCRIPTION
1393	SPRING PIN
1513	E4 CLIP-ON-WASHER
8400	E5 CLIP-ON-WASHER
61333	M4 SCREW
61343	M4 SCREW
73944	THRUST WASHER
75055	BELT ROLLER
75083	GEAR A
75214	INDICATOR
76655	BEVEL GEAR
76678	SHAFT
76679	TORSION SPRING
76701	BELT
76702	SHAFT
76739	PATTERN SELECTING DIAL
76803	SEAL
77042	M4 PHILLIPS SCREW

BUYER'S MODEL NO.	314	SECTION	PAGE	REVISION	REMARKS
FACTORY MODEL NAME	CE313ED	-	9		
ORIGINAL ISSUE	September, 2002	SERIAL NO.			

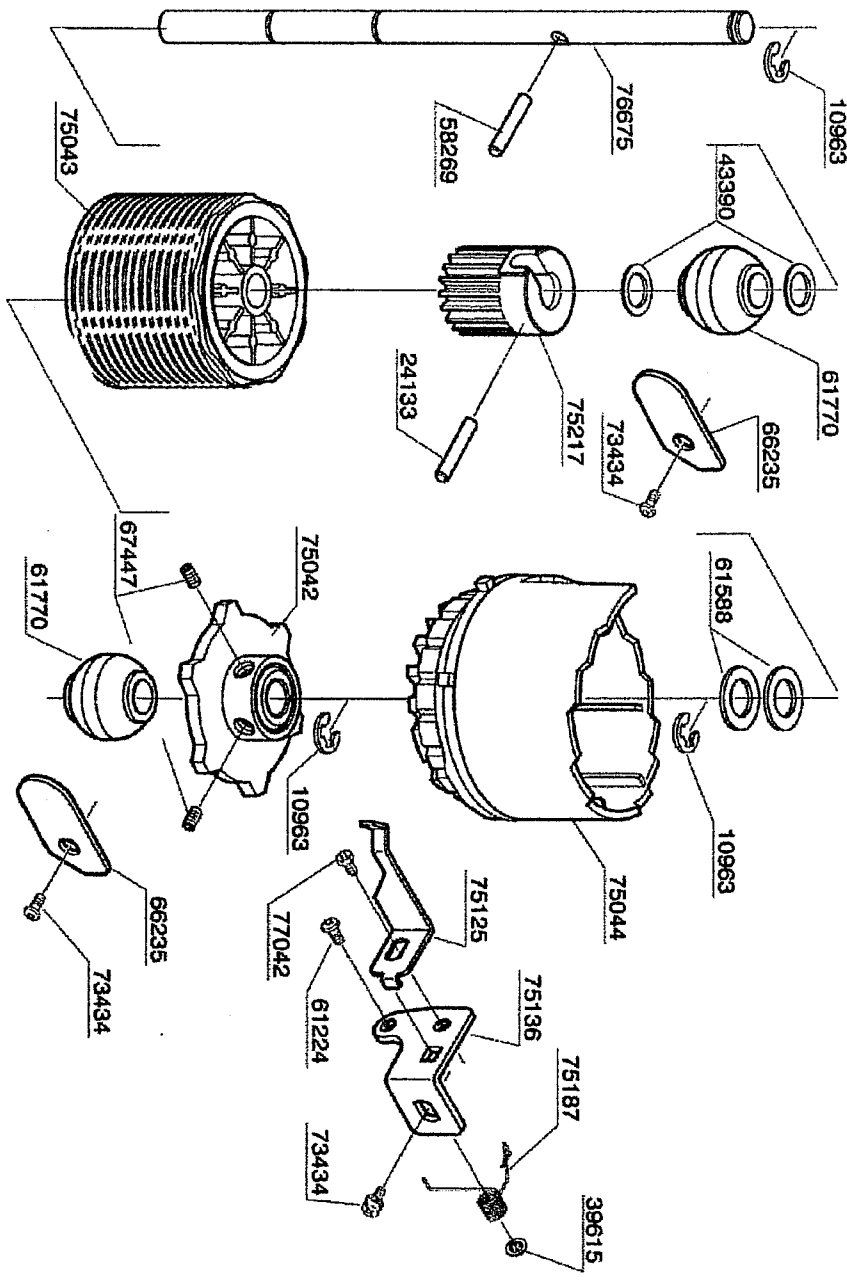

PART NO.	DESCRIPTION
10963	E6 CLIP-ON-WASHER
24133	SPRING PIN
39615	CLIP-ON-WASHER
43390	THRUST WASHER
58269	SPRING PIN
61224	M4 PHILLIPS SCREW
61588	WASHER
61770	BALL BUSHING
66235	SECURING PLATE
67447	M5 SCREW
73434	M4 PHILLIPS SCREW
75042	STRETCH STITCHING CAM
75043	PATTERN CAM
75044	PATTERN SELECTING CAM
75125	LEAF SPRING
75136	BRACKET
75187	TORSION SPRING
75217	WORM GEAR
76675	SHAFT
77042	M4 PHILLIPS SCREW

BUYER'S MODEL NO.	314	SECTION		PAGE	10	REVISION		REMARKS	
BUYER'S MODEL NAME	CE313ED								
FACTORY MODEL	September, 2002	SERIAL NO.							
ORIGINAL ISSUE									

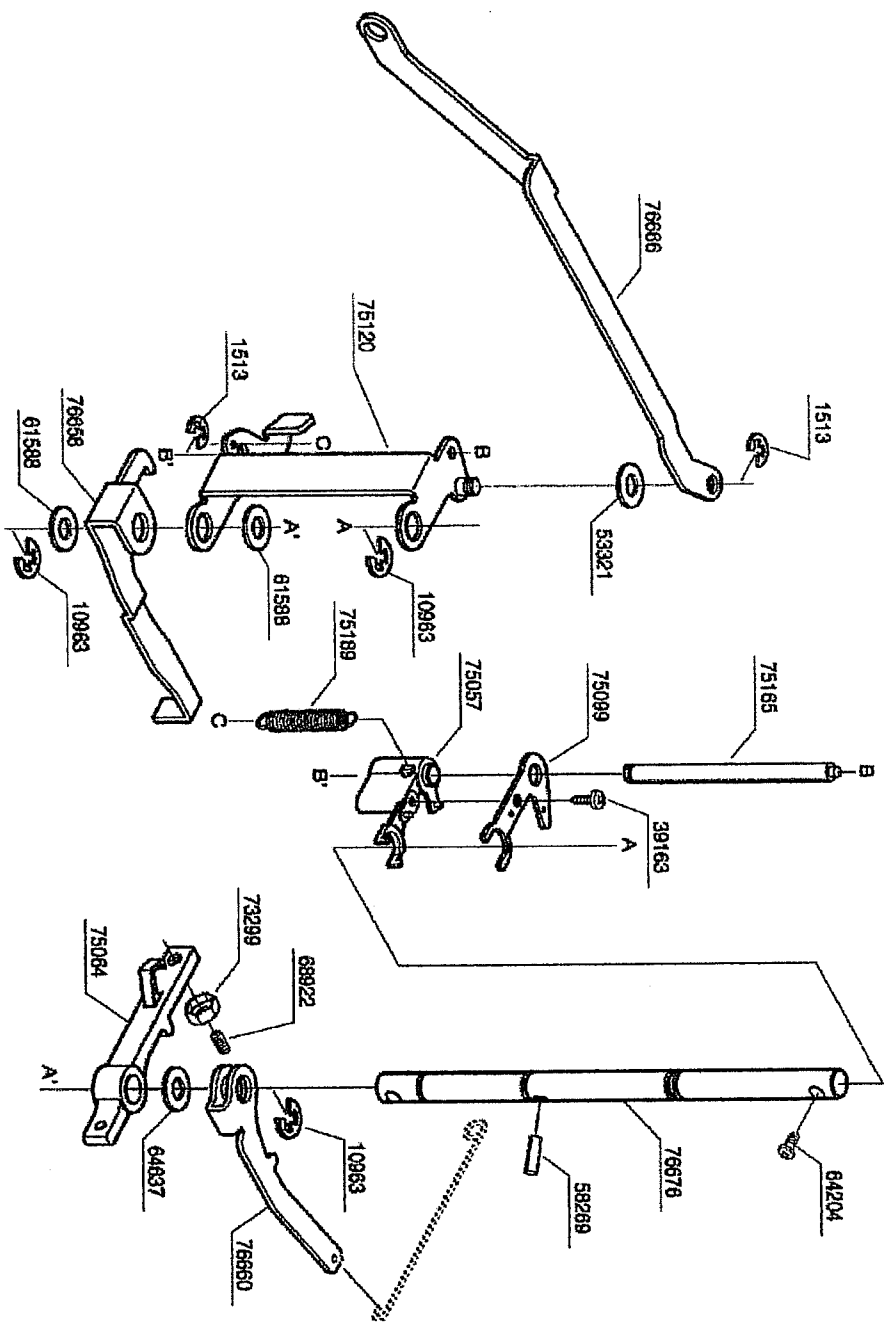

PART NO.	DESCRIPTION
1513	E4 CLIP-ON-WASHER
10963	E6 CLIP-ON-WASHER
39163	TAPPING SCREW
53321	THRUST WASHER
58269	SPRING PIN
61588	THRUST WASHER
64204	M4 PHILLIPS SCREW
64637	THRUST WASHER
68922	M4 SCREW
73299	M4 TORQUE NUT
75057	ZIGZAG GUIDE BLOCK
75064	PATTERN SELECTING CAM CLAW
75099	PATTERN CAM FOLLOWER
75120	CAM FOLLOWER GUIDE BRACKET
75165	SHAFT B
75189	EXTENSION SPRING
76658	STRETCH STITCHING CAM FOLLOWER
76660	BH CAM FOLLOWER
76666	ZIGZAG GUIDE BAR
76676	SHAFT A

BUYER'S MODEL NO.	314	SECTION		PAGE	11	REVISION		REMARKS	
FACTORY MODEL	CE313ED								
ORIGINAL ISSUE	September, 2002			SERIAL NO.					

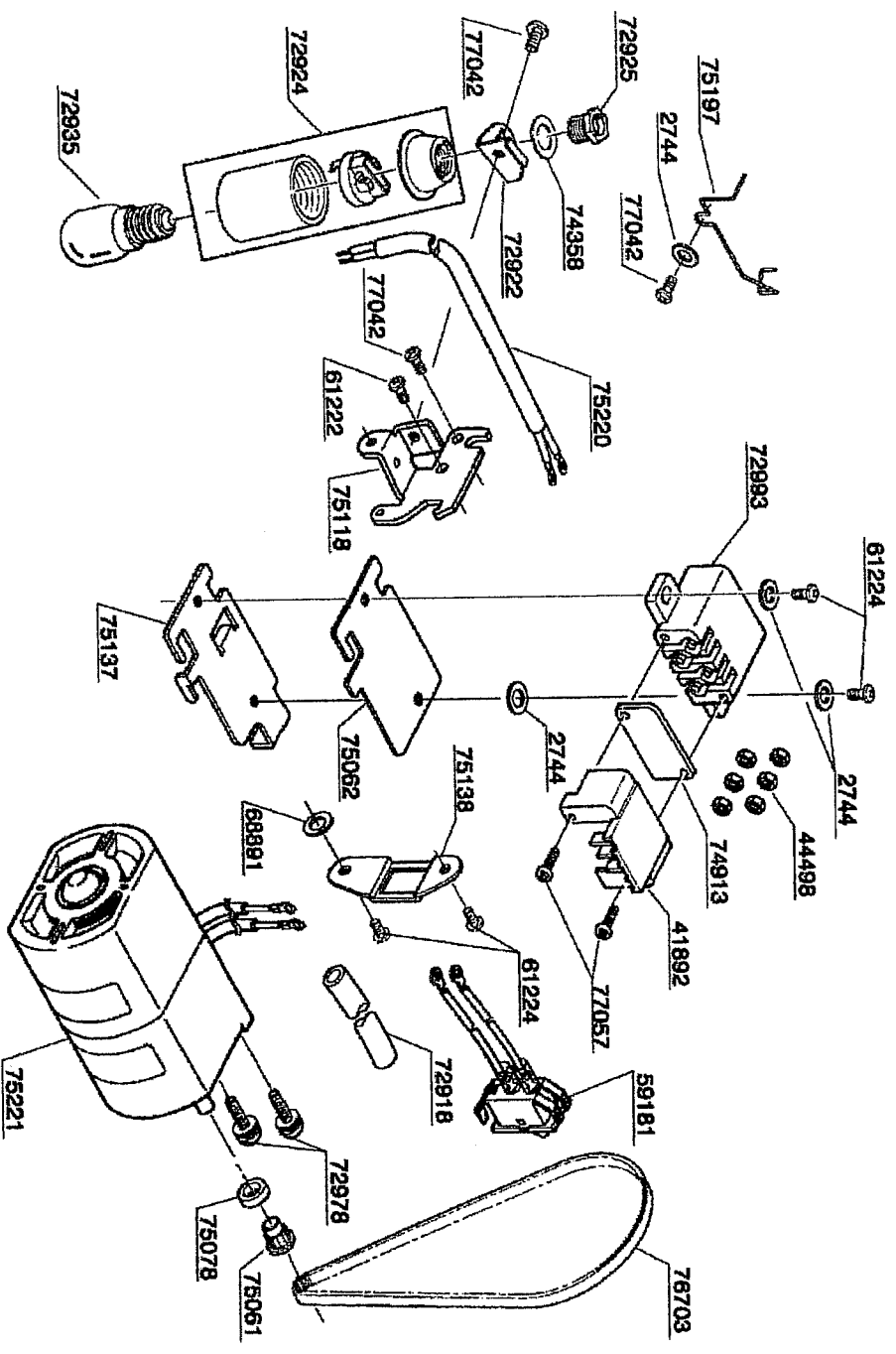

PART NO.	DESCRIPTION
2744	WASHER
41892	TERMINAL BLOCK COVER
44498	M3 NUT
59181	SWITCH ASSEMBLY
61222	M4 PHILLIPS SCREW
61224	M4 PHILLIPS SCREW
68991	WASHER
72918	VINYL TUBE
72922	LAMP HOLDER BRACKET
72924	LAMP HOLDER ASSEMBLY
72925	CAP BOLT
72935	LIGHT BULB
72978	M4 BOLT WITH WASHER
72993	TERMINAL BLOCK ASSEMBLY
74913	WASHER
74913	TERMINAL BLOCK COVER
75061	MOTOR PULLEY
75062	INSULATING SHEET
75078	MOTOR PULLEY FLANGE
75118	LAMP PLATE BRACKET
75137	TERMINAL BLOCK BRACKET
75138	SWITCH BRACKET
75197	CORD GUIDE
75220	LAMP CORD
75221	MOTOR (230V)
76703	MOTOR BELT
77042	M4 PHILLIPS SCREW
77057	M3 PHILLIPS SCREW

BUYER'S MODEL NO.	314	SECTION		PAGE	12	REVISION		REMARKS	
BUYER'S MODEL NAME	CE313ED								
FACTORY MODEL	September 2002	SERIAL NO.							
ORIGINAL ISSUE									

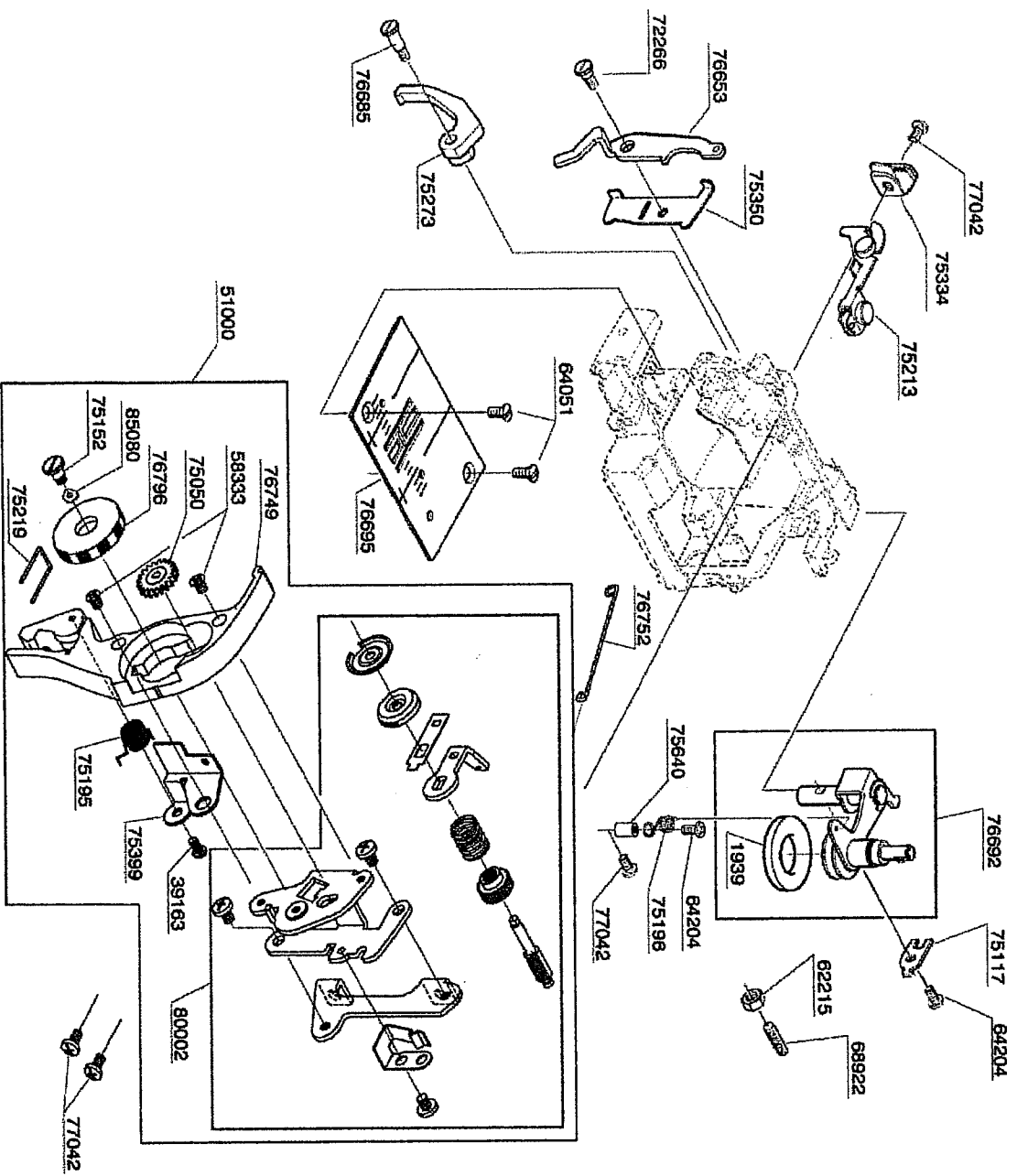

PART NO.	DESCRIPTION
1939	RUBBER RING
39163	M3 PHILLIPS SCREW
51000	THREAD GUIDE PLATE UNIT
58333	M4 COUNTERSUNK HEAD SCREW
62215	M4 NUT
64051	M4 SCREW
64204	M4 PHILLIPS SCREW
68922	M4 SCREW
72266	M4 STUD SCREW
75050	DIAL GEAR
75117	PLATE
75152	STUD SCREW
75195	TORSION SPRING
75196	TORSION SPRING
75213	THREAD GUIDE PLATE
75219	THREAD SPRING
75273	PRESSER FOOT LIFTER
75334	THREAD GUIDE PLATE
75350	STOPPER
75399	THREAD COVER
75640	VINYL TUBE
76533	TENSION RELEASE LEVER
76885	M4 STUD SCREW
76892	BOBBIN WINDER COMPLETE
76895	NEEDLE PLATE
76749	THREAD TENSION PLATE
76752	TENSION RELEASE BAR
76796	THREAD TENSION DIAL
77042	M4 PHILLIPS SCREW
80002	THREAD TENSION DIAL ASSEMBLY
85080	CRINKLE WASHER

BUYER'S MODEL NO.	314	SECTION		PAGE	13	REVISION		REMARKS
BUYER'S MODEL NAME								
FACTORY MODEL	CE313ED							
ORIGINAL ISSUE	September, 2002	SERIAL NO.						

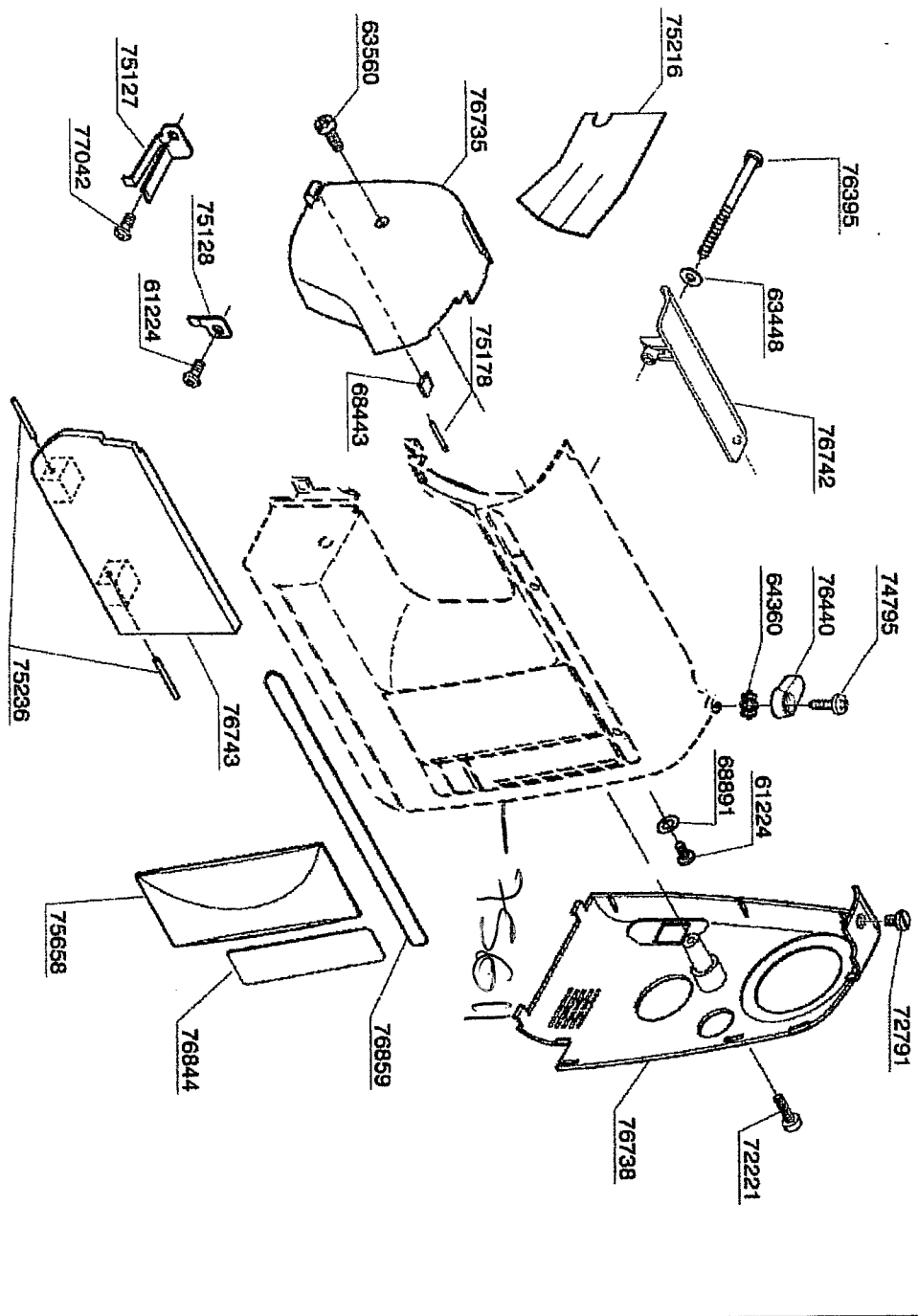

PART NO.	DESCRIPTION
61224	M4 PHILLIPS SCREW
63448	WASHER
63560	M4 PHILLIPS SCREW
64360	TOOTHED WASHER
68443	BLADE
68891	WASHER
72221	M4 STUD SCREW
72791	M4 SCREW
74795	TAPPING SCREW
75127	LEAF SPRING
75128	SECURING PLATE
75178	PIN
75216	REFLECTION SHEET
75236	PIN
75658	PLATE
76395	TAPPING SCREW
76440	PLASTIC COLLAR
76735	FACE COVER
76738	SIDE COVER
76742	HANDLE
76743	SHUTTLE RACE COVER
76844	CONTROL PLATE
76859	PLATE
77042	M4 PHILLIPS SCREW

1-1-21

L74909

L77117

Maketa. 76769
