

SIRUBA

使用說明書與零件圖

INSTRUCTIONS BOOK & PARTS LIST

DL7500

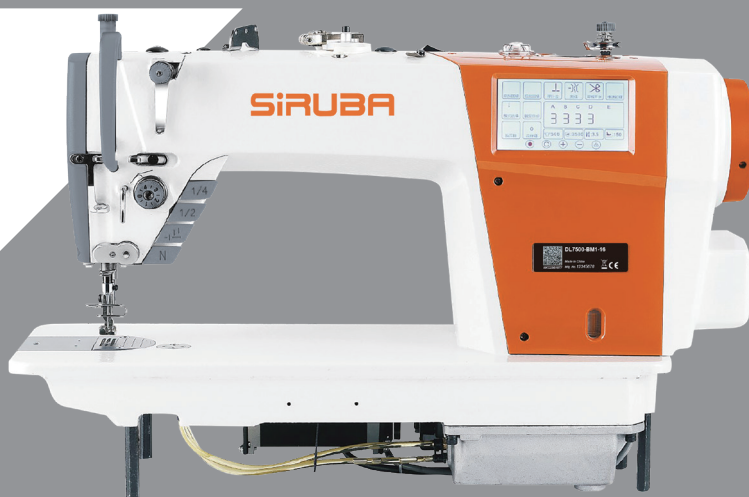

重要安全事項

為使您正確使用我們的產品，須對產品的各種功能充分了解，以便安全操作。使用前請仔細閱讀使用說明書。我們希望您能長期愉快地使用我們的產品，請保存好說明書，以備查閱。

1. 使用此縫紉機時，必須遵守包括如下項目的基本安全措施。
2. 使用此縫紉機之前，請閱讀本使用說明書在內的所有指示文件。
同時應將此使用說明書妥善保管，以便能夠隨時查閱。
3. 此縫紉機應與貴國的有關安全規定一起使用。
4. 使用此縫紉機和縫紉機動作中，所有的安全裝置應安裝到規定的位置。
沒有安裝規定的安全裝置的縫紉機禁止使用。
5. 此縫紉機應由接受過培訓的操作人員來操作。
6. 使用縫紉機時，建議戴安全防護眼鏡。
7. 發生下列情況時，應立即關掉電源開關，或拔下電源插頭。
 - 7-1 機針、彎針、分離器等穿線和更換旋梭時。
 - 7-2 更換機針、壓腳、針板、彎針、分離器、送布牙、護針器、支架向導器等時。
 - 7-3 修理時。
 - 7-4 工作場所無人了或離開工作場所時。
8. 縫紉機以及附屬裝置使用的機油、潤滑脂等液體流入眼睛或沾到皮膚上時，或被誤飲時，應立即清洗有關部分並去醫院治療。

9. 禁止用手觸摸打開了縫紉機開關通電的零件或裝置。
10. 有關縫紉機的修理、改造、調整應由受過專門訓練的技術人員或專家進行。
11. 一般的維修保養應由受過訓練的人員來進行。
12. 有關縫紉機的電氣方面的修理、維修應由資格的電氣技術人員或專家的監督和指導下進行。
13. 修理、保養有關空氣、氣缸等壓縮空氣的零件時，應切斷空氣壓縮機供氣源後再進行。如有殘留壓縮空氣時，應放掉壓縮空氣。
14. 縫紉機在其使用其間應定期清掃。

15. 為了正常安全運轉，應安裝地線。同時應在不受高頻焊接機等強噪音源影響的環境下使用。
16. 電源插頭應用具有電氣專門知識來安裝。電源插頭必須連接到接地插座上。

17. 縫紉機指定用途以外不能使用。
18. 對縫紉機的改造、變更應符合安全規格，並採取有獎的安全措施。
另外，對於有關改造和變更，公司概不負責。

19. 本使用說明書上採用以下2個警告符號。

 有損傷操作人員、維修人員的危險。

 安全上需要特別加以注意的事項。

IMPORTANT SAFETY INSTRUCTIONS

To get the most out of the many functions of this machine and operate it in safety, it is necessary to use this machine correctly. Please read this instruction Manual carefully before use. We hope you will enjoy the use of your machine for a long time. Please remember to keep this manual in a safe place.

1. Observe the basic safety measures, including, but not limited to the following ones, whenever you use the machine.
2. Read all the instructions, including, but not limited to this Instruction Manual before you use the machine. In addition, keep this Instruction Manual so that you read it at anytime when necessary.
3. Use the machine after it has been ascertained that it conforms with safety rules/standards valid in your country.
4. All safety device must be in position when the machine is ready for word or in operation.
The operation without the specified safety devices is not allowed.
5. This machine shall be operated by appropriately-trained operators.
6. For your personal protection, we recommend that you wear safety glasses.
7. For the following, turn off the power switch or disconnect the power plug of the machine from the receptacle.
 - 7-1 For threading needle(s), looper, spreader etc. And replacing bobbin.
 - 7-2 For replacing part(s) of needle, presser foot, throat plate, looper, spreader, feed dog, needle guard, folder, cloth guide ect.
 - 7-3 For repair work.
 - 7-4 When leaving the work place or when the working place is unattended.
8. If you should allow oil, grease, etc. Use with the machine and devices to come in contact with your eyes or skin or swallow any of such liquid by mistake, immediately wash the contacted areas and consult a medical doctor.

9. Tampering with the live parts and devices, regardless of whether the machine is powered, is prohibited.
10. Repair, remodeling and adjustment works must only be done by appropriately trained technicians or specially skilled Personnel. Only spare parts designated by can be used for repairs.
11. General maintenance and inspection works have to be done by appropriately trained personnel.
12. Repair and maintenance works of electrical components shall be conducted by qualified electric technicians or under the audit and guidance of specially skilled personnel.
13. Before making repair and maintenance works on the machine equipped with pneumatic parts such as an air cylinder, the air compressor has to be detached from the machine and the compressed air supply has to be cut off. Existing residual air pressure after disconnecting the air compressor from the compressed air supply has to be expelled. Exceptions to this are only adjustments and performance checks done by appropriately trained technicians or specially skilled personnel.
14. Periodically clean the machine throughout the period of use.

15. Grounding the machine is always necessary for the normal operation of the machine. The machine has to be operated in an environment that is free from strong noise sources such as high-frequency welder.
16. An appropriate power plug has to be attached to the machine by electric technicians. Power plug has to be connected to a grounded receptacle.

17. Grounding the machine is always necessary for the normal operation of the machine. The machine has to be operated in an environment that is free from strong noise sources such as high-frequency welder.
18. An appropriate power plug has to be attached to the machine by electric technicians. Power plug has to be connected to a grounded receptacle.

19. Warning hints are marked with the two shown symbols.



Danger of injury to operator or service staff



Items requiring special attention

安全操作事項 FOR SAFE OPERATION

 <p>危險 DANGER</p>	<p>1. 為了防止發生觸電事故，請不要再打開電源的狀態下，打開電氣箱蓋以及觸摸電氣箱內的零件。</p> <p>1. To avoid electrical shock hazards, neither open the cover of the electrical box for the motor nor touch the components mounted inside the electrical box.</p>
 <p>注意 CAUTION</p>	<p>1. 為了防止人身事故的發生，請不要再卸下電機罩、手指防護器等安全裝置的狀態下運轉縫紉機。</p> <p>2. 為了防止被卷入機器的人身事故，縫紉機運轉中請不要將手指、頭發、衣服靠近手輪、也不要將東西放到機器上面</p> <p>3. 為了防止人身事故的發生，打開電源時以及縫紉機運轉中，請不要把手指放到機針附近。</p> <p>4. 為了防止人身事故的發生，縫紉機運轉中請不要反手指放到挑線桿外罩內。</p> <p>5. 縫紉機操作中，旋梭高速地旋轉。為了防止手受到傷害，運轉中請絕對不要把手靠近旋梭。</p> <p>6. 為了防止人身事故的發生，放到縫紉機或返回原來位置時，要注意不要夾住手。</p> <p>7. 為了防止突然的起動造成人身事故，放到縫紉機時，請一定關掉電源。</p> <p>8. 使用伺服電機時，縫紉機停止電機無聲音。為了防止意外的起動造成人身事故，請注意不要忘記關電源。</p> <p>9. 為了防止觸電事故，卸下電源地線的狀態，請不要運轉縫紉機。</p> <p>10. 為了防止觸電和損壞電氣零件，拔電源的插頭時，請先關掉機器電源開關。</p> <p>1. To avoid personal injury, never operate the machine with any of the belt cover, finger guard or safety devices removed.</p> <p>2. To prevent possible personal injuries caused by being caught in the machine, keep your fingers, head and clothes away from the handwheel, V belt and the motor while the machine is operation. In addition, place nothing around them.</p> <p>3. To avoid personal injury, never put your hand under the needle when you turn "ON" the power switch or operate the machine.</p> <p>4. To avoid personal injury, never put your fingers into the thread take-up cover while the machine is operation.</p> <p>5. The hook rotates at a high speed while the machine is in operation. To prevent possible injury to hands, be sure to keep your hands away from the vicinity of the hook during operation. In addition, be sure to turn OFF the power to the machine when replacing the bobbin.</p> <p>6. To avoid possible personal injuries, be careful not to allow your fingers in the machine when tilting/raising the machine head.</p> <p>7. To avoid possible accidents because of abrupt start of the machine, turn OFF the power to the machine when tilting the machine head.</p> <p>8. If your machine is equipped with a servo-motor does not produce noise while the machine when tilting the machine head.</p> <p>9. To avoid electrical shock hazards, never operate the sewing machine with the ground wire for the power supply removed.</p> <p>10. To prevent possible accidents because of electric shock or damaged electrical components(s), turn OFF the power switch in prior to the connection/disconnection of the power plug.</p>

運轉縫紉機前的注意事項 BEFORE OPERATION



注意
CAUTION

為了防止機械錯誤動作或損傷，請確認如下項目。

To avoid malfunction and damage of the machine, confirm the following.

- 最初使用縫紉機之前，請把機器打掃乾淨。
- 清除運送中積存的灰塵，並加油。
- 請確認電壓是否正確。
- 請確認電源插頭是否正確接連。
- 電壓規格不同時，請絕對不要使用。
- 縫紉機的轉動方向是，站在飛輪側看為逆時針方向。請注意不要讓縫紉機反向轉動。
- Before you put the machine into operation for the first time after the set up, clean it thoroughly.
- Remember all dust gathering during transportation and oil it well.
- Confirm that the power plug has been properly connected to the power supply.
- Never use the machine in the state where the connected to the power supply.
- The direction of rotation of the sewing machine is counterclockwise as observed from the handwheel side. Be careful not to rotate it in reverse direction.

1. 縫紉機規格 MACHINE SPECIFICATIONS

		M	H
用途 USE		薄料、中厚料 Medium-weight materials	厚料 Heavy-weight materials
最高縫紉速度 Max.sewing speed		4500 sti/min	4500 sti/min
最大針距 Max.stitch speed		5mm	7mm
壓腳高度 Presser foot height	壓腳扳手 Lifting lever	6mm	6mm
	自動 Automatic	6-10mm 可調 (Adjustable)	6-10mm 可調 (Adjustable)
送布牙高度 Feed dog height		1.0mm	1.2mm
機針 (DB×1, DP×5) Needle		#9-#18	#19-#22
潤滑油		10號白油 No.10 white oil	

2-1.台板加工圖 Table processing diagram

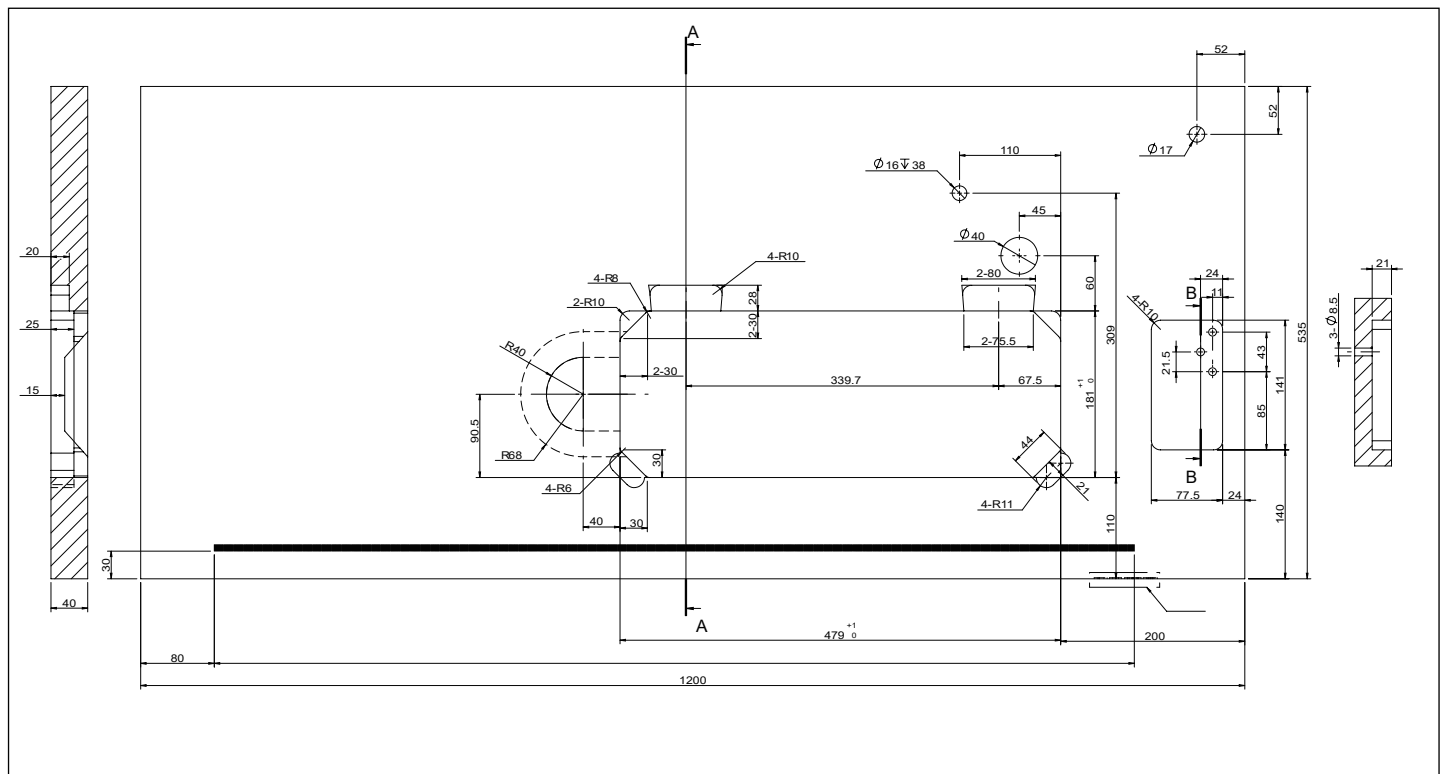

2-2.安裝方法 Installation

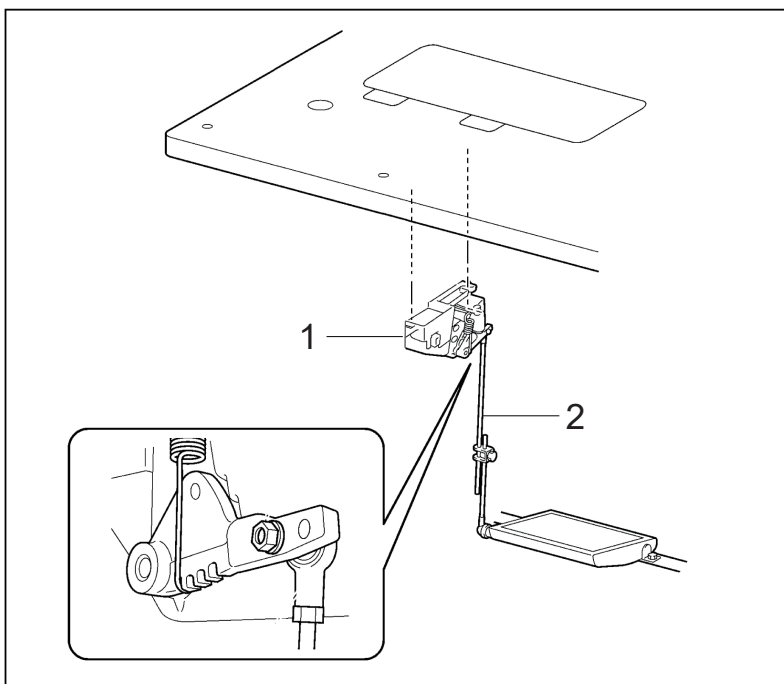

1.調速器
1.Governor

2.連桿
2.Connecting rod

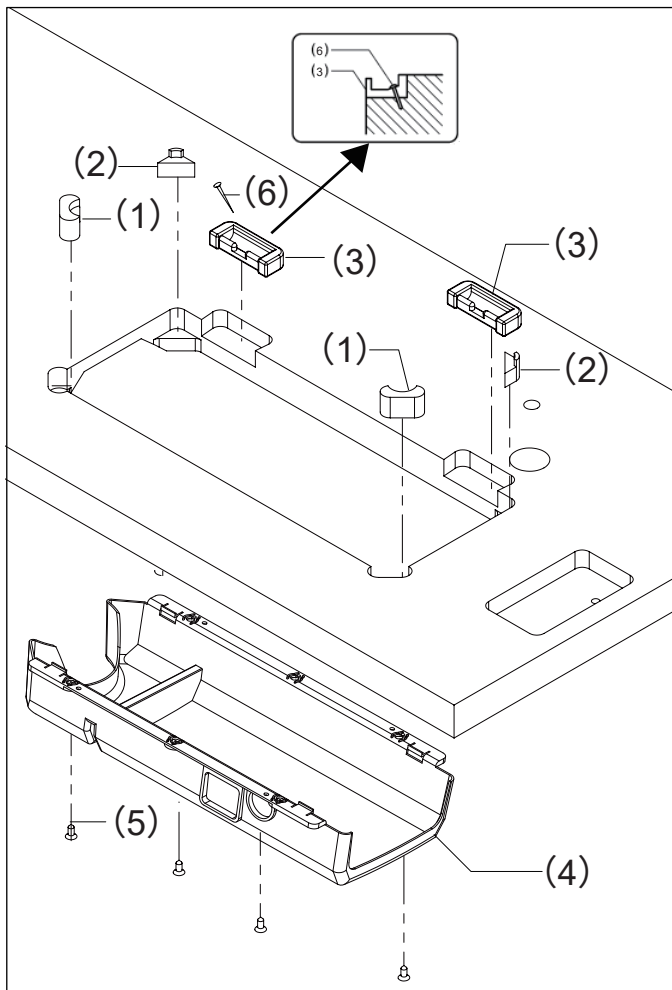

3. 安裝

- (1) 頭部防震墊 (大) (2個)
- (2) 頭部防震墊 (小) (2個)
- (3) 鉸鏈套 (2個)
- (4) 托盤
- (5) 螺釘 (4個)
- (6) 釘 (8個)

3. Install

- (1) Head cushions(big)[2 pcs]
- (2) Head cushions(small)[2 pcs]
- (3) Rubber cushions[2 pcs]
- (4) Tray
- (5) Screw [4 pcs]
- (6) Nail [8 pcs]

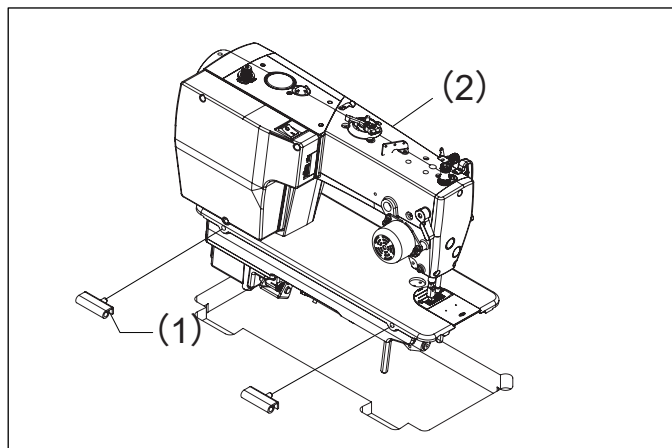

4. 縫紉機頭部

- (1) 機頭鉸鏈 (2個)
- (2) 縫紉機頭部

4. Machine head

- (1) Hinges [2 pcs]
- (2) Machine head

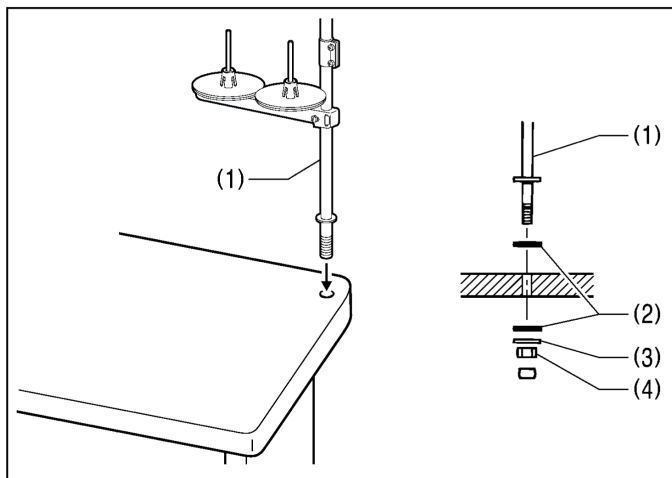

5. 線架

- (1) 線架

注意：將螺母 (4) 擰緊以便將兩個橡皮墊片 (2) 和墊圈 (3) 夾緊，使線架 (1) 固定。

5. Cotton stand







- (1) Cotton stand

NOTE:

Securely tighten the nut(4) so that the two rubber cushions(2) and the washer(3) are securely clamped and so that the cotton stand(1) does not move.

3.加油方法 Lubrication

注意 CAUTION

-  在加油未完成前，請勿插上電源。
當誤踩下踏腳板時，縫紉機動作會導致人員受傷。
-  使用潤滑油時，請務必戴好保護眼鏡和保護手套等，以防潤滑油落入眼中或沾在皮膚上，這是引起發炎的原因。
另外，潤滑油不能飲用，否則會引起嘔吐和腹瀉。
將油放在兒童拿不到的地方。
-  在剪去油罐的油嘴口時，請一定要拿住油嘴的根部。
如果拿住油嘴口，剪刀容易傷到手，成為受傷的原因。
-  Do not connect the power cord until lubrication has been completed, otherwise the machine may operate if the treadle is depressed by mistake, which could result in injury.
-  Be sure to wear protective goggles and gloves when handling the lubricating oil and grease, so that they do not get into your eyes or onto your skin, otherwise inflammation can result.
Furthermore, do not drink the oil or eat the grease under any circumstances, as they can cause vomiting and diarrhea.
Keep the oil out of the reach of children.
-  When cutting the nozzle of the oil tank, hold the base of the nozzle securely.
If you hold the end of the nozzle, injury from the scissors may result.

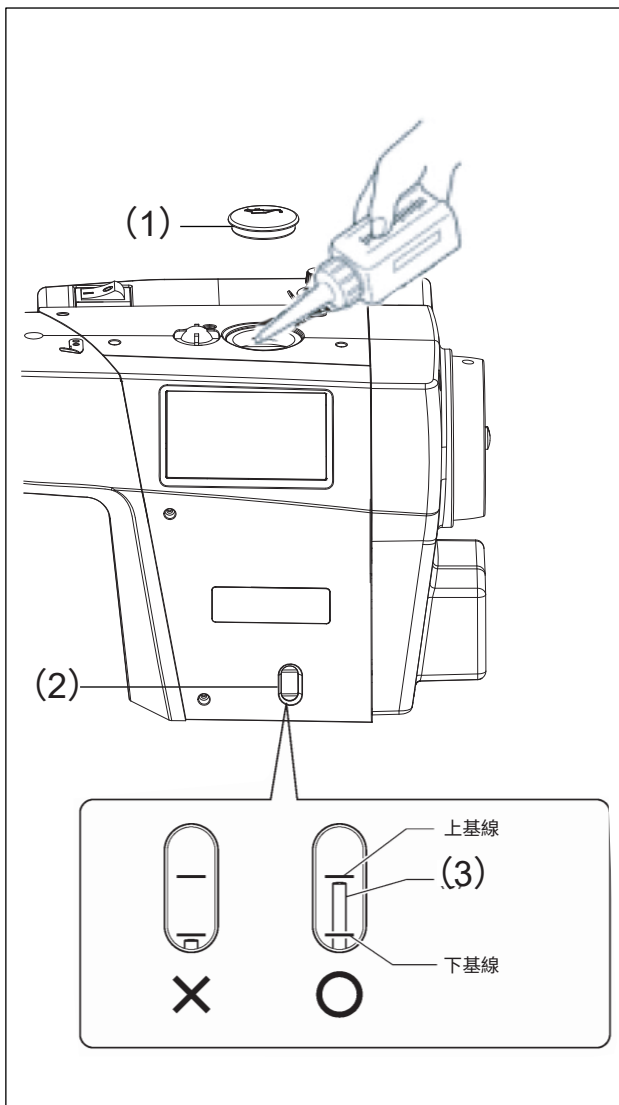

初次使用縫紉機前需添加機油以保證機器各部機械部件的潤滑，以延長機器壽命

- 1.將加注機油孔塞 (1) 打開
- 2.將白油注入機頭加油口中
- 3.加油過程中觀察油量視窗 (2)，使油量計 (3) 穩定在上、下基線之間

注：油量計不可超過視窗上基線

如油量計 (3) 低於下基線，則必須添加機油

Before the first time use this sewing machine, you need to add oil to ensure the lubrication of the mechanical parts of the machine, to prolong the service life of the machine

1. open the oil rubber (1)
 2. add oil into the machine
 3. look at the oil window (2) during adding oil, to make the oil gauge (3) is steable between the top and bottom baselines
- Note: the oil gauge can't be over the top baseline in the window

If the oil gauge (3) is lower than the buttom baseline, machine must be added oil

4.面線的穿法 THREADING THE UPPER THREAD

⚠ 注意 CAUTION



在穿線過程中，請切斷電源。當誤按動起動開關時，縫紉機動作會導致人員受傷。
Turn off the power switch before threading the upper thread.
The machine may operate if the treadle is depressed by mistake, which could result in injury.

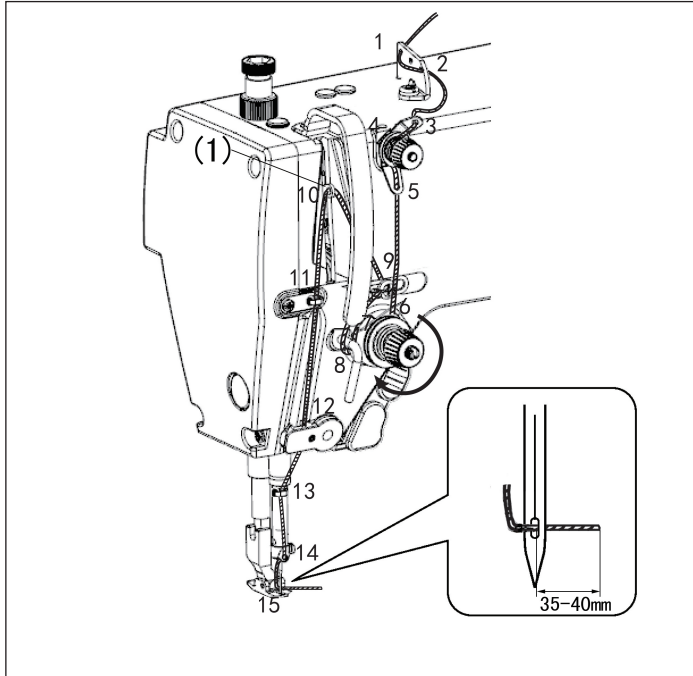

·在穿引面線之前轉動手輪，抬高挑線桿（1）。這樣會使穿引更加容易，並防止面線在縫紉開始時脫落

·Turn the machine pulley and raise the thread take-up(1) before threading the upper thread. This will make threading easier and it will prevent the thread from coming out at the sewing start.

5.機針和旋梭的同步 Adjusting the needle and rotary hook timing

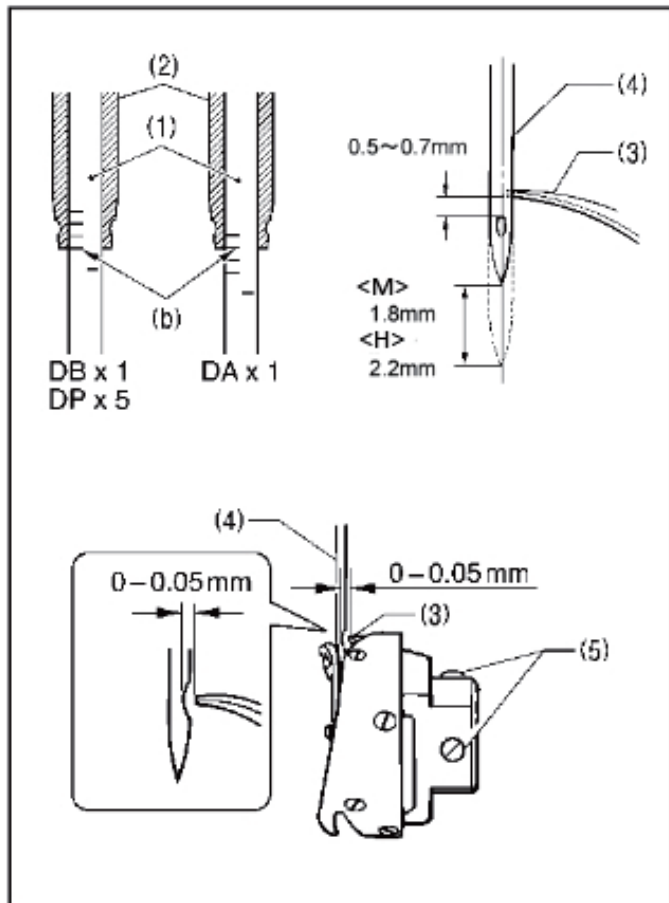

當針桿(1)從最低位置向上移動1.8mm(2.2mm用於M和H規格)，到達基線(b)與針桿軸套(2)下端對齊的位置時，旋梭尖端(3)應與機針中心(4)對齊，如圖所示。

(此時，針孔上邊緣與旋梭尖的距離為0.5至0.7mm。)

1.轉動縫紉機手輪，使針桿(1)從最低位置上升到如圖所示的基線(b)與針桿軸套(2)的下端保持對齊為止。
2.旋鬆固定螺釘(5)[3個]，使旋梭尖(3)與機針(4)的中心一致。

此時，旋梭尖(3)與機針(4)之間的間隙為0~0.05mm
3.擰緊固定螺釘(5)[3個]。

The tip of the rotary hook (3) should be aligned with the center of the needle (4) when the needle bar (1) moves up 1.8mm (2.2mm for -M and -H specifications) from its lowest position to the position where reference line (b) is aligned with the lower edge of the needle bar bush (2) as shown in the illustration. (The distance from the upper edge of the needle hole to the rotary hook tip will be 0.5 to 0.7mm at this time.)

1. Turn the machine pulley to raise the needle bar (1) from its lowest position until reference line (b) is aligned with the lower edge of the needle bar bush D (2) as shown in the illustration.
2. Loosen the set screws (5), and then align the tip of the rotary hook (3) with the center of the needle (4).

The distance between the tip of the rotary hook (3) and the needle (4) should be approximately 0-0.05mm.

3. Securely tighten the set screws (5).

6. 踏板的調整 ADJUSTMENT OF THE PEDAL



注意

為了防止意外的起動造成的事故，請關掉電源後進行。

WARNING:

Turn off the power before starting the work so as to prevent accidents caused by abrupt start of the sewing machine.

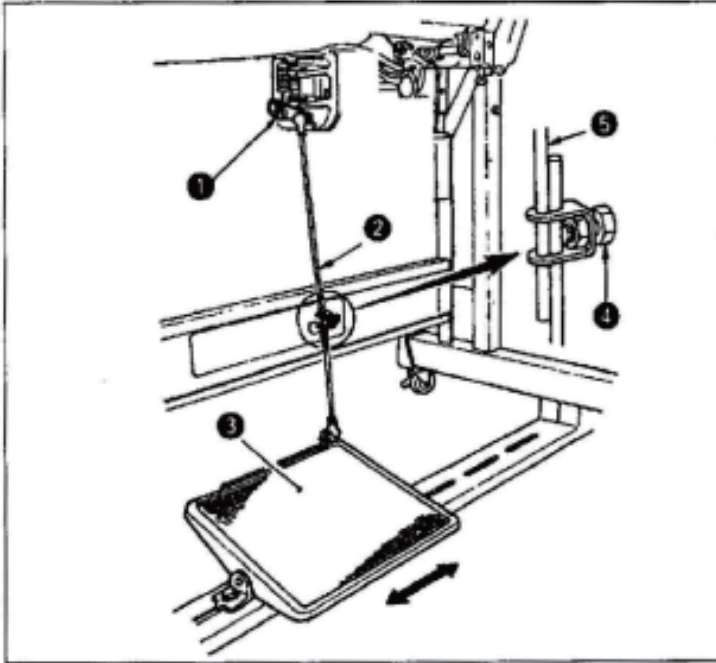

(1) 連接桿的安裝

1) 向箭頭方向移動踏板調節板③，讓踏板撥桿①和連接桿②呈一直線。

(2) 踏板的角度

1) 調節連接桿的長度就可以自由地改變踏板的傾斜角度。

2) 擰鬆調節螺絲④，拉出插入連接桿⑤進行調整。

(1) Installing the connecting rod

1) Move pedal ③ to the right or left as illustrated by the arrow so that motor control lever ① and connecting rod ② are straightened.

(2) Adjusting the pedal angle

1) The pedal tilt can be freely adjusted by changing the length of the connecting rod.

2) Loosen adjust screw ④, and adjust the length of connecting rod ⑤.

踏板操作 / PEDAL OPERATION

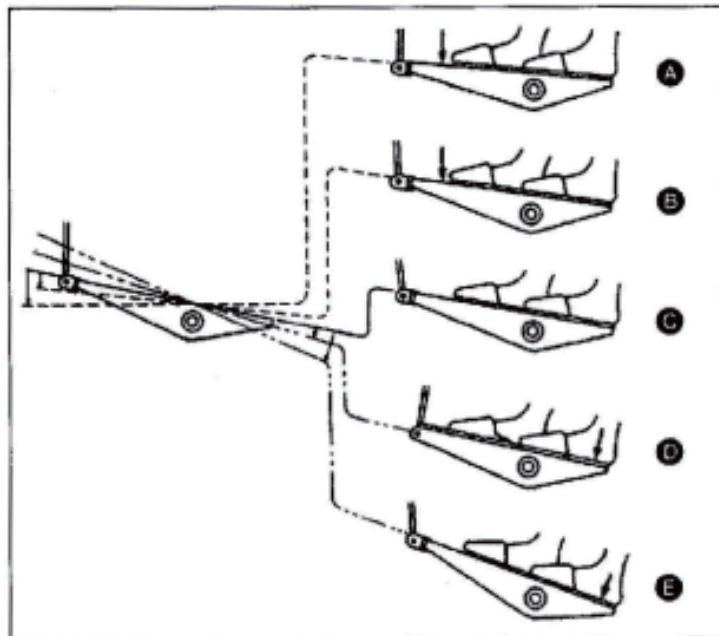

(1) 踏板按4個階段進行操作。

1) 向前輕輕踩踏板為低速縫制 (B)

2) 再用力向前踩踏板則變為告訴縫制 (A)

(但是，開關設定為自動倒縫時，倒縫結束後進行高速縫制)

3) 把踏板返回到腳輕輕地放到踏板上的位置縫紉機停止 (C)。(機針上停止或下停止位置)

4) 用力向後踩踏板則為切線動作 (E)

* 使用自動壓腳提升裝置時，再停止和切線之間增加1級開關。向後輕輕的踩踏板為壓腳提升動作 (D) 再往後用力踩踏板為切線動作。

(1) The pedal is operated in the following four steps:

1) The machine runs at low sewing speed when you lightly depress the front part of the pedal (B).

2) The machine runs at high sewing speed when you lightly depress the front part of the pedal (A).

(If the automatic reverse feed stitching has been preset, the machine runs at high speed after it completes reverse feed stitching)



3) The machine stops (with its needle up or down) when you reset the pedal to its original position (C).

4) The machine trims threads when you fully depress the back part of the pedal (E).







* If your machine is provided with the Auto-lifter an addition step is given between the machine stop and thread Trimming step. The presser foot goes up when you lightly depress the back part of the pedal (D), and if you further depress the back part, the thread trimmer is actuated.

7.標準調整 STANDARD ADJUSTMENT

⚠ 注意

-  只有經過訓練的技術人員才能進行縫紉機的維修，保養和檢查。
-  縫紉機頭倒下或豎起時，請用雙手進行操作。單手造作時因縫紉機的重量萬一滑落易導致受傷。
-  與電氣有關的維修、保養和檢查請委托購買商店或電氣專業人員進行。
-  發生下列情況時，請關閉電源。並拔下電源插座。否則誤踩下踏腳板時，縫紉機動作會導致受傷。
 - 檢查、調整和維修
 - 更換旋梭，切刀等易損零部件
-  取下的安全保護裝置，再次安裝時，請務必安裝在原位上，並檢查能否正常的發揮作用。
-  在必須接上電源開關進行調整時，務必十分小心遵守所有的安全注意事項。

⚠ CAUTION

-  Maintenance and inspection of the sewing machine should only be carried out by a qualified technician.
-  Use both hands hold the machine head when tilting it back or returning it to its original position. If only one hand is used, the weight of the machine head may cause your hand to slip, and your hand may get caught.
-  Ask your DUMA dealer or a qualified electrician to carry out any maintenance and inspection of the electrical system.
-  Turn off the power switch and disconnect the power cord from the wall outlet at the following times, otherwise the machine may operate if the treadle is depressed by mistake, which could result in injury.
 - When carrying out inspection, adjustment and maintenance
 - When replacing consumable parts such as the rotary hook and knife
-  If any safety devices have been removed, be absolutely sure to re-install them to their original positions and check that they operate correctly before using the machine.
-  Secure the table so that it will not move when tilting back the machine head. If the table moves, it may crush your feet or cause other injuries.

7-1.機殼線導向R Adjusting arm thread guide R

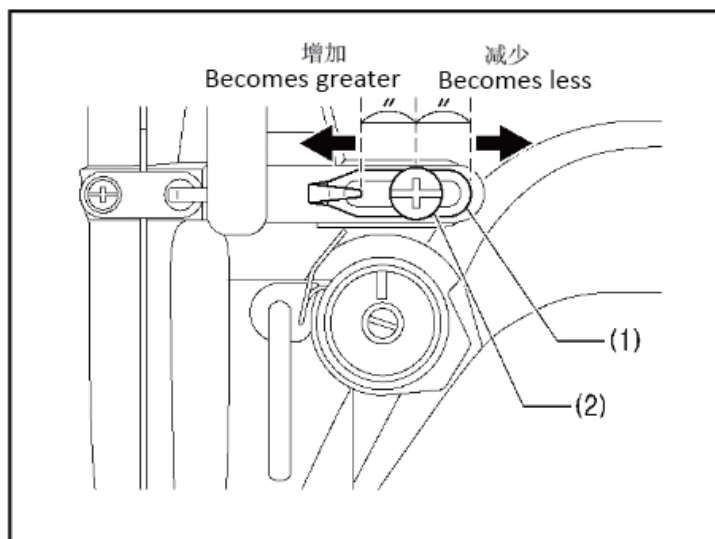

機殼線導向R(1)的標準安裝位置是在螺釘 (2) 位於機殼線導向R(1) 的可調範圍中心處。

[注意]

旋鬆螺釘 (2) ，移動機殼線導向R (1) 進行位置的調節。

- 當縫紉厚料時，向左移動機殼線導向R (1) 。（挑線量增加。）
- 當縫紉厚料時，向右移動機殼線導向R (1) 。（挑線量減少。）

The standard position of arm thread guide R (1) is the position where the screw (2) is in the center of the adjustable range for arm thread guide R (1) .

To adjust the position, loosen the screw (2) and then move arm thread guide R (1) .

- When sewing thick material, move arm thread guide R (1) to the left. (The thread take-up amount will become greater.)
- When sewing thin material, move arm thread guide R (1) to the right. (The thread take-up amount will become less.)

7-2.送布牙的高度

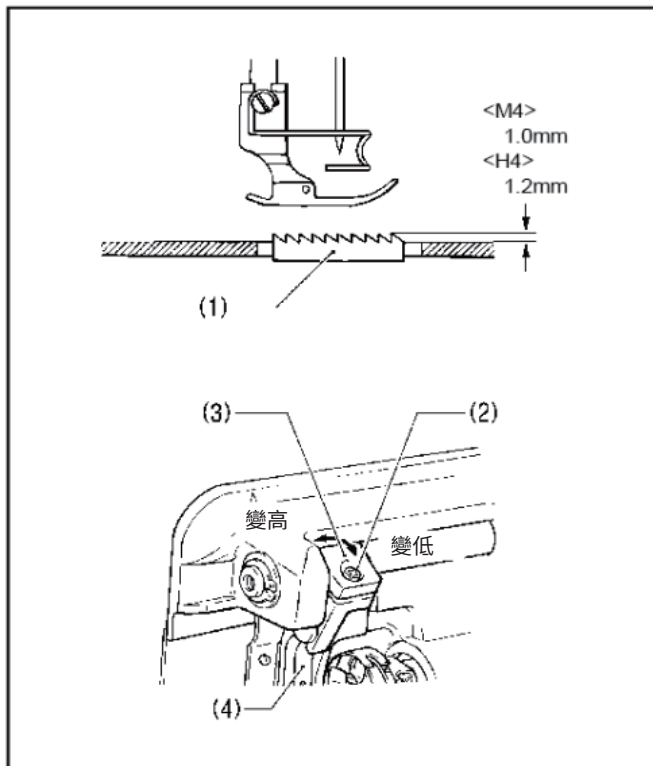

當送布牙 (1) 被盡量提高到針板表面之上時，其標準高度為1.0mm (用於M規格) 和1.2mm (用於H規格)。

- 1.回轉縫紉機手輪，將送布牙(1)移到針板上方最高處。
- 2.放倒縫紉機機頭。
- 3.旋鬆螺釘 (2)。
- 4.旋轉上下抬牙叉 (3) 來調整。
- 5.擰緊螺釘 (2)。

7-3.送布牙的角度

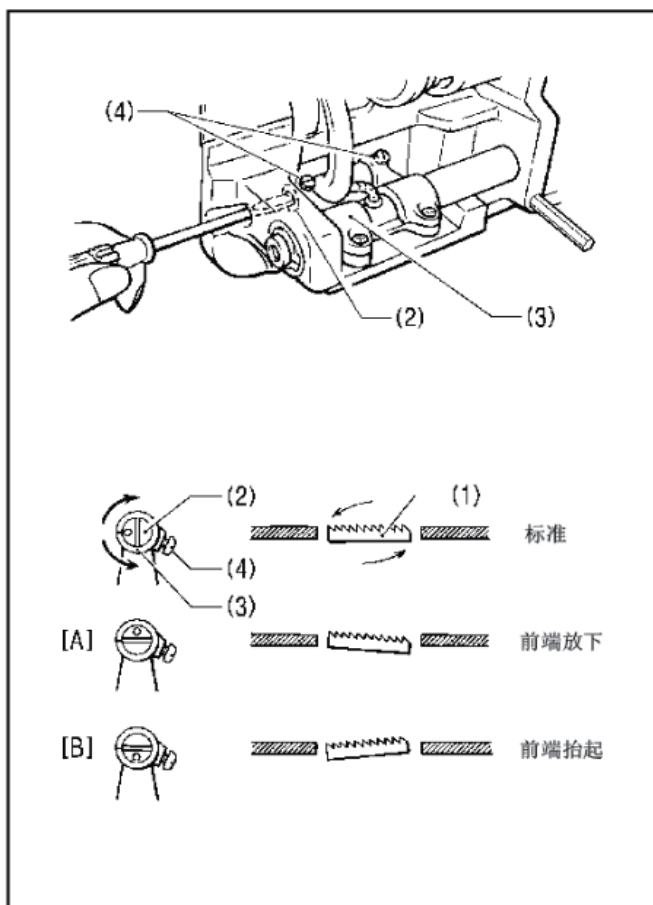

送布牙 (1) 位於針板最高處時的標準傾斜是牙架曲柄偏心軸 (2) 上的鋼印 (O) 與牙架曲柄 (3) 上的標記一致，送布牙 (1) 與針板平行。

- 1.轉動縫紉機手輪，將送布牙 (1) 移到針板上方最高處的位置。
- 2.放倒縫紉機機頭。
- 3.將螺釘 (4) [2個]鬆開。
- 4.根據標準位置，在90°的範圍內按箭頭方向調整牙架曲柄偏心軸 (2)。
- 為了防止起皺，可降低送布牙 (1) 的前端。(圖A)
- 為了防止在重疊縫紉時布料不一致[縫線不合]，可抬高送布牙 (1) 的前端。(圖B)
- 5.將螺釘 (4) [2個]完全擰緊。

[注意]

調整送布牙 (1) 的傾斜度後，送布牙 (1) 的高度也會改變，因此請再一次調整送布牙 (1) 的高度。

7-2.Adjusting the feed dog height

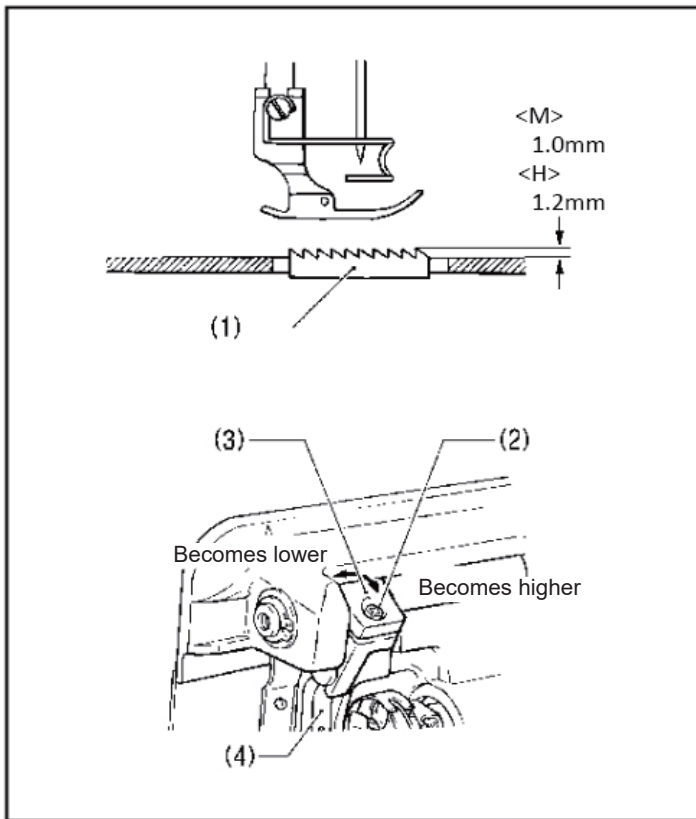

The standard height of the feed dog (1) when it is at its maximum height above the top of the needle plate is 1.0 mm for M specifications, and 1.2mm for H specifications.

1. Turn the pulley until the feed dog (1) rises to the highest Position.
2. Tilt back the machine head.
3. Loosen the screw (2).
4. Move the feed bar(3) up or down to make adjustment.
5. Tighten the screw (2).

7-3.Adjusting the feed dog angle

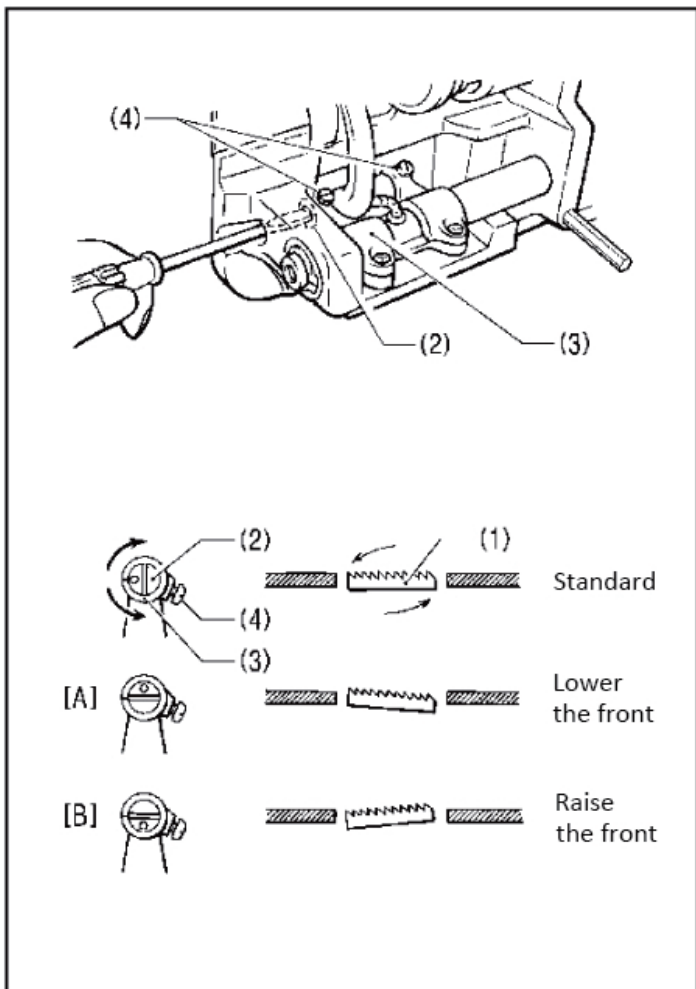

The standard angle for the feed dog (1) when it is at its highest position above the needle plate is when the “O” mark on the shaft (2) is aligned with the feed rocker bracket arm (3) and the feed dog (1) is parallel to the needle plate.

1. Make the machine hand wheel backward, rise the feed dog from lowest position to the same position with needle plate.
2. Tilt back the machine head.
3. Loosen the two set screws (4).
4. Turn the shaft (2) in the direction of the arrow within a range of 90 with respect to the standard position. (Fig.[C])
In order to prevent puckering, lower the front of the feed dog (1).
In order to prevent the material from slipping, raise the front of the feed dog (1).
5. Securely tighten the set screws (4),

8. 線張力的調節 Adjusting the thread tension

⚠ 注意 CAUTION

取出梭芯套時，請切斷電源。



當誤踩下踏腳板時，縫紉機動作會導致人員受傷。

Turn off the power switch before removing or inserting the bobbin case.

The machine may operate if the treadle is depressed by mistake, which could result in injury.

正確的針跡 Good even stitches





面線張力過小或底線張力過大。
Upper thread tension too weak
Lower thread tension too strong

→

增大面線張力。減小底線張力。
Increase the upper thread tension.
Decrease the lower thread tension.



面線張力過大或底線張力過小。
Upper thread tension too strong
Lower thread tension too weak

→

減小面線張力。增大底線張力。
Decrease the upper thread tension.
Increase the lower thread tension.

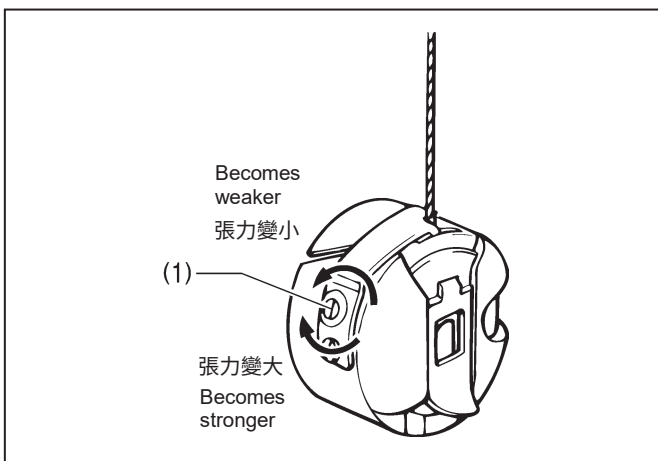

<底線張力>

拉住從梭芯套中露出的線頭，轉動調節螺釘(1)進行調節直至梭芯套以自重慢慢垂落。

<Lower thread tension>

Adjust by turning the adjustment screw (1) until the bobbin case drops gently by its own weight while the thread end coming out of the bobbin case is held.

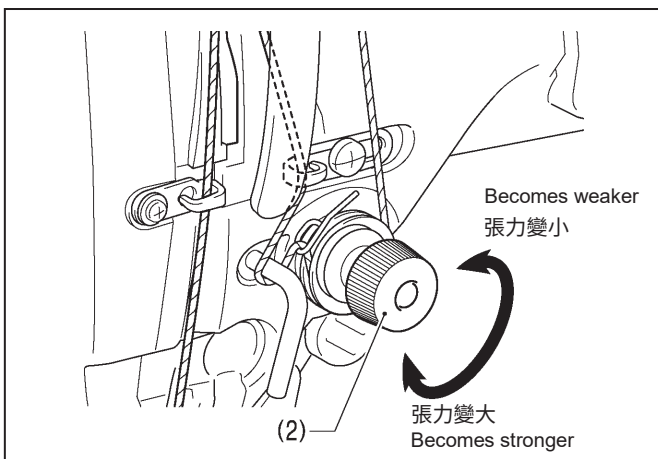

<面線張力>

在底線張力調節之後，調節面線張力以使針腳均勻平整。

1. 降下壓腳。
2. 轉動夾線螺母(2)進行調節。

<Upper thread tension>

After the lower thread tension has been adjusted, adjust the upper thread tension so that a good, even stitch is obtained.

1. Lower the presser foot.
2. Adjust by turning the tension nut (2).

9.旋梭供油量的調整

⚠ 注意



在檢查旋梭供油量時,手指和油量測試紙不能碰到旋梭和送布機構等運動零部件。
是導致人員受傷的原因。

如更換了旋梭或要變更縫紉速度時,請按下述步驟調整旋梭的供油量。

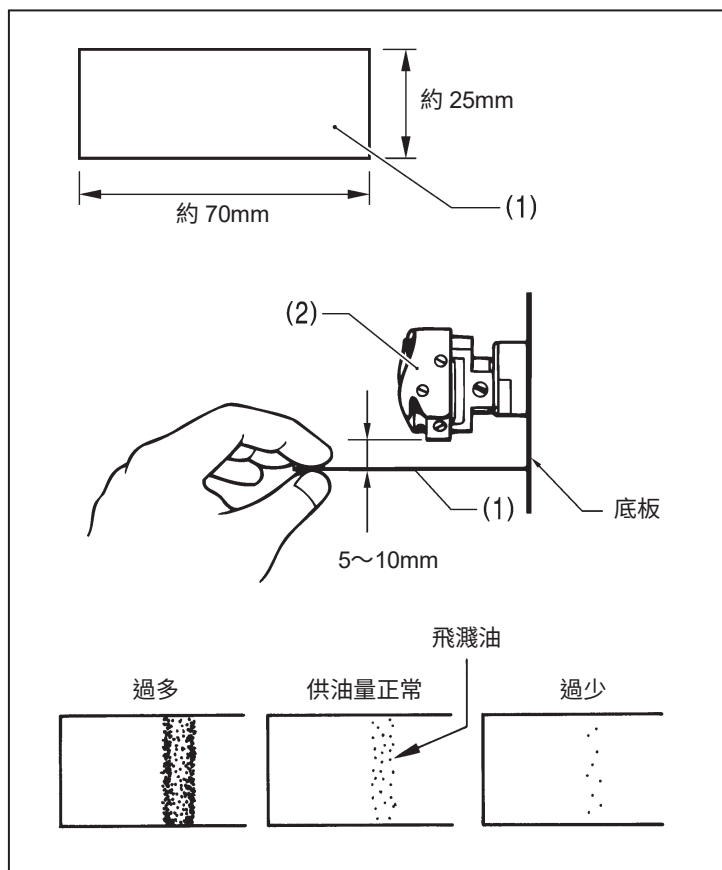

<供油量的確認>

1. 拆去挑線桿至機針上的線。
2. 用抬壓腳扳手抬起壓腳。
3. 以縫紉機實際縫紉時的轉速進行約 10 分鐘的空運轉 (適度的斷續運轉)。
4. 將油量測試紙(1)插入旋梭(2)的下面並握住,以縫紉機實際進行縫紉時的轉速使縫紉機運轉 10 秒鐘。(對油量測試紙(1)的紙質沒有什麼要求。)
5. 確認飛濺到測試紙上的油量。

當需要進行調整時,請按下面(供油量的調整)一節所述進行調整。

[注意]

如果供油量的檢查結果不符合左圖所示的狀態(飛濺到紙上的油跡呈完整的帶狀或一點也沒有飛濺出來),則請向右轉動油量調整螺釘(3)將其完全擰入,然後再向左轉動擰出 3 圈半,在鬆開的狀態下進行下述的調整作業。

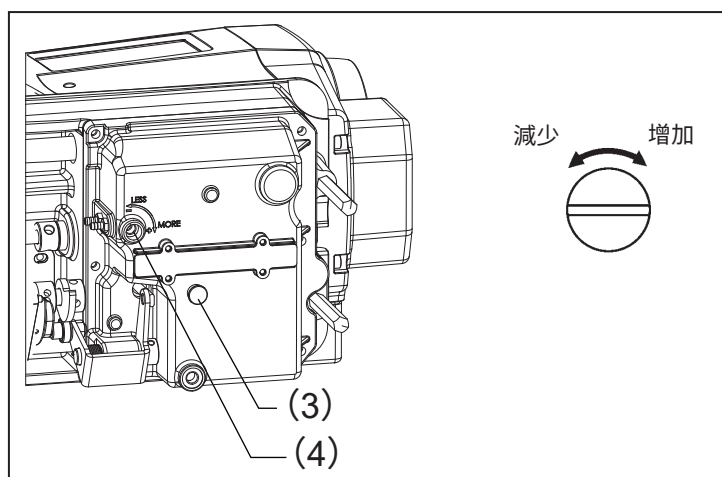

<供油量的調整>

1. 將縫紉機頭部倒下。
2. 取出橡皮塞 (3)。
3. 轉動油量調整螺釘 (4), 調整供油量。
 - 向右轉動油量調整螺釘 (3), 供油量增加
 - 向左轉動油量調整螺釘 (3), 供油量減少。
4. 參照上述 [供油量的確認] 所述來檢查供油量。
 - * 請反覆轉動油量調整螺釘, 進行調整及供油量的確認, 直到獲得適當的供油量為止。
5. 將橡皮塞裝回原處。
6. 在進行了約 2 小時的縫紉後, 請再次檢查供油量。

9. Adjusting the rotary hook lubrication amount

! CAUTION



Be careful not to touch your fingers or the lubrication amount check sheet against moving parts such as the rotary hook or the feed mechanism when checking the amount of oil supplied to the rotary hook. If care is not taken, injury may result.

Use the following procedure to check the amount of oil being supplied to the rotary hook when replacing the rotary hook or when changing the sewing speed.

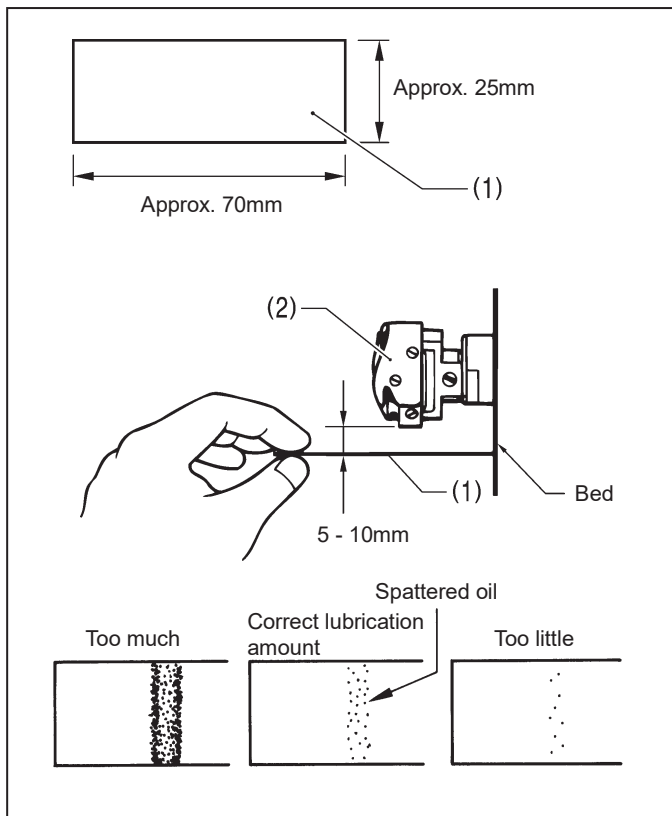

<Checking the lubrication amount>

1. Remove the thread from all points from the thread take-up lever to the needle.
2. Use the lifting lever to lift the presser foot.
3. Run the machine at the normal sewing speed for approximately 10 minutes without sewing any material (following the same start/stop pattern as when actually sewing).
4. Place the lubrication amount check sheet (1) to the left of the rotary hook (2) and hold it there. Then run the sewing machine at the normal sewing speed for 10 seconds. (Any type of paper can be used as the lubrication amount check sheet (1).)
5. Check the amount of oil which has spattered onto the sheet.

If adjustment is necessary, carry out the following operations in "Adjusting the lubrication amount".

NOTE:

If the lubrication amount does not match the correct amount shown in the illustration at left (if the amount of spattered oil is too much or none at all), turn the adjusting screw (3) clockwise to fully tighten it, turn it back counterclockwise by 3 1/2 turns, and then carry out the following adjustment.

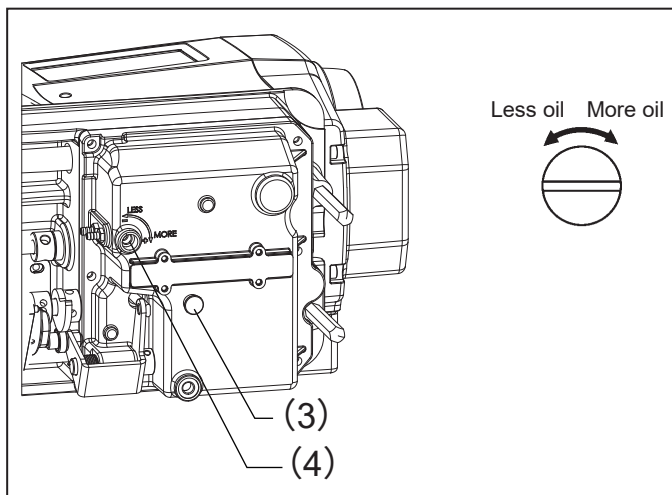

<Adjusting the lubrication amount>

1. Tilt back the machine head.
2. Remove the rubber cap (3).
3. Turn the adjusting screw (4) to adjust the lubrication amount.
 - If the rotary hook adjusting screw (4) is turned clockwise, the lubrication amount becomes greater.
 - If the rotary hook adjusting screw (4) is turned counterclockwise, the lubrication amount becomes smaller.
4. Check the lubrication amount again according to the procedure given in "Checking the lubrication amount" above.
 - * Turn the rotary hook adjusting screw (4) and check the lubrication amount repeatedly until the lubrication amount is correct.
5. Put the rubber (3) stopper back in place .
6. Check the lubrication amount again after the sewing machine has been used for approximately two hours.

10. 切線

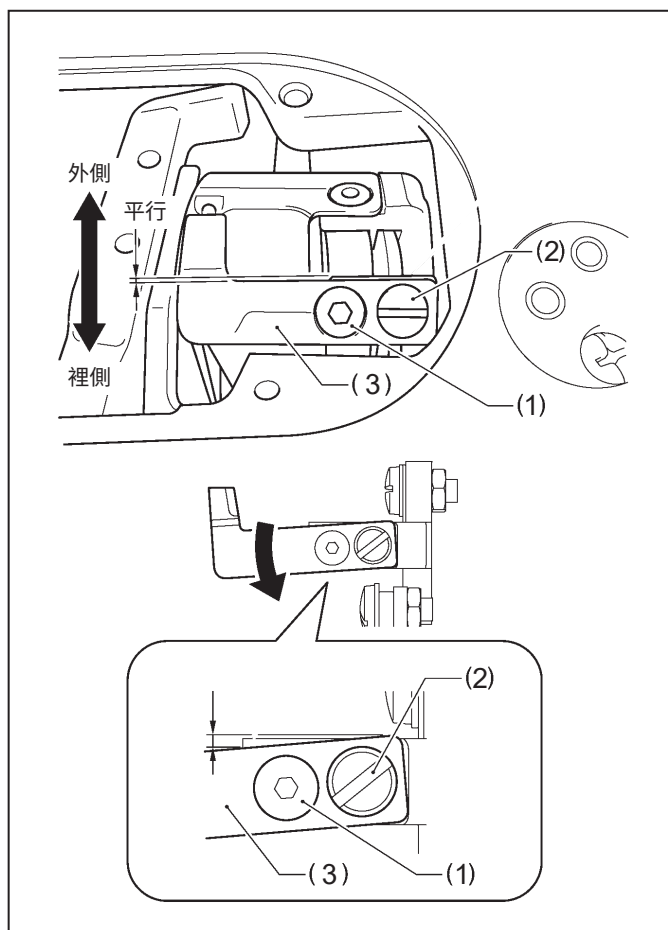

1. 使用粗線或不能切線時，將螺釘 (1) 和螺釘 (2) 鬆開，調整上動刀 (3) 角度。
2. 上動刀 (3) 向裡側傾斜時刀面壓力上升，向外側傾斜時刀面壓力下降。
3. 調整好上動刀 (3) 角度後重新擰緊螺釘 (1) 和螺釘 (2)。
4. 調整後請手動上下動刀架，確認是否可以正常切線。

11. 膝控安裝

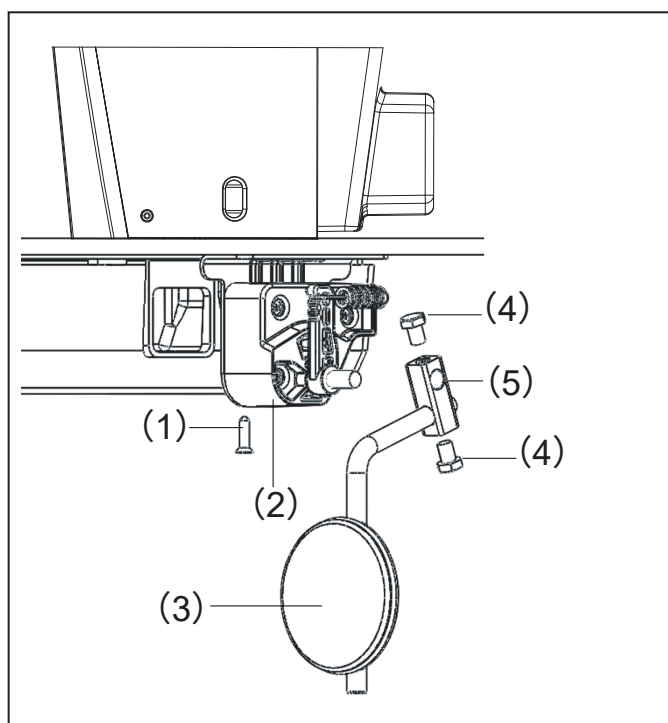

1. 將電子膝靠組件 (2) 固定在台板上，旋緊固定螺釘 (1)。
2. 將膝控組件 (3) 與膝控接頭 (5)、電子膝靠組件 (2) 連接。
3. 擰緊螺釘 (4)
4. 安裝後檢查膝控組件是否靈活。

10. Thread trimming

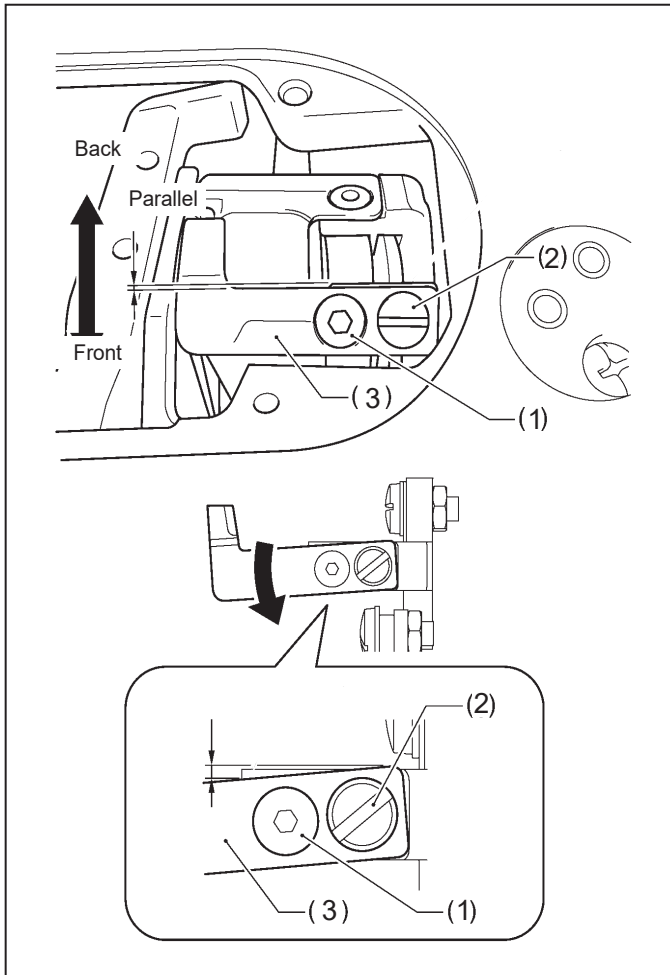

1. When use thick thread or not trim, loosen the screw (1) and (2), adjust the moving knife (3) angle.
2. Knife (3) tilted to the inside, the knife surface pressure rise. Slanting outward, the knife surface pressure drop.
3. Adjust the knife (3) anger,then re tighten the screw (1) and screw (2).
4. After adjustment, manually move up and down the knife holder to confirm whether the machine can trim thread normally or not.

11. Knee control installation

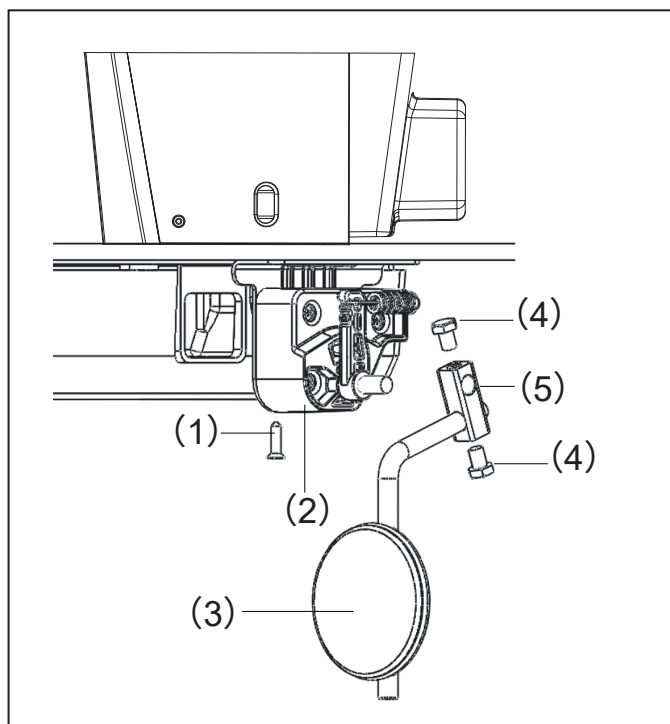

1. The electronic knee assembly (2) is fixed on the plate and the fixed screw (1) is tightened.
2. Connect the knee control assembly (3) with the knee control joint (5) and the electronic knee assembly (2).
3. Tighten the screw (4) .
4. Check whether the knee control is flexible after installation.

SIRUBA PARTS LIST	Series	Parts Group	Subclass Remark	Page
	DL7500			1 / 1
				Date
				2022/01/13

1.機體部分/Machine body

A

B

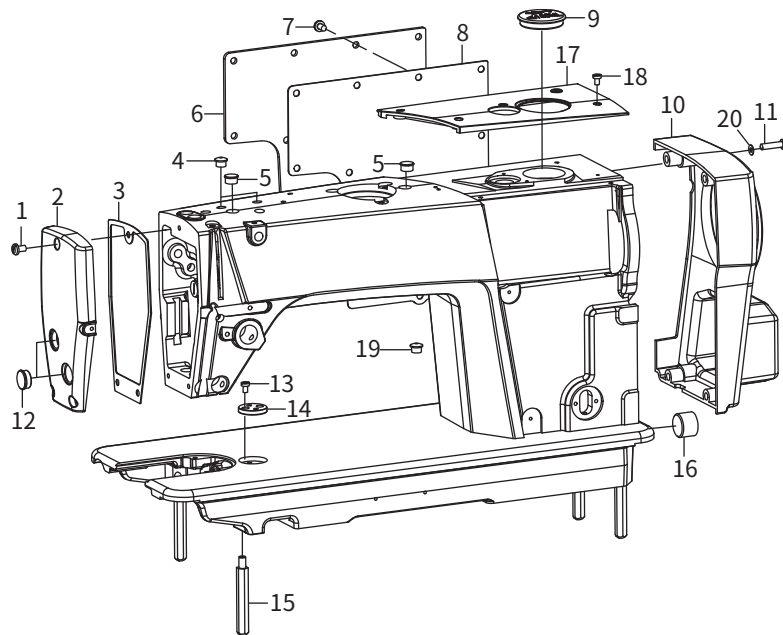

C

D

E

序號	圖號	數量	零件名稱	NAME OF PARTS
1	062710812	3	螺釘 SM4.76-28x9	SCREW PAN SM4.76-28x9
2	168012201	1	面板	FACE PLATE
3	168012301	1	面板墊	GASKET
4	115011401	2	橡皮塞 8.5	RUBBER 8.5
5	101011001	2	橡皮塞 12.5	RUBBER 12.5
6	115010401	1	后窗板	SIDE PLATE
7	062501216	9	螺釘 M5×12	SCREW PAN M5×12
8	115010501	1	后窗板襯墊	GASKET
9	168010901	1	橡皮塞 37.8	RUBBER 37.8
10	168012101	1	馬達罩	MOTOR COVER
11	018502532	4	螺釘 M5×25	SCREW PAN M5×25
12	115010701	2	橡皮塞 15.5	RUBBER 15.5
13	101013201	2	螺釘 SM4.37-40x5.5	SCREW PAN SM4.37-40x5.5
14	101012601	1	卷邊器座	EDGE WINDING DEVICE
15	168011701	4	底板支柱	BED SCREW STUD
16	101011401	1	橡皮塞 20.9	RUBBER 20.9
17	168012001	1	頂蓋	UPPER COVER
18	168012501	5	螺釘 M3×8	SCREW PAN M3×8
19	101013301	1	孔塞8.8	STOPPLE 8.8
20	025050132	4	墊圈 5	WASHER 5

1

2

3

4

5

SIRUBA PARTS LIST	Series	Parts Group	Subclass Remark	Page
	DL7500			1 / 1
				Date
				2022/01/13

2.上軸裝置/Shaft mechanism

A

B

C

D

E

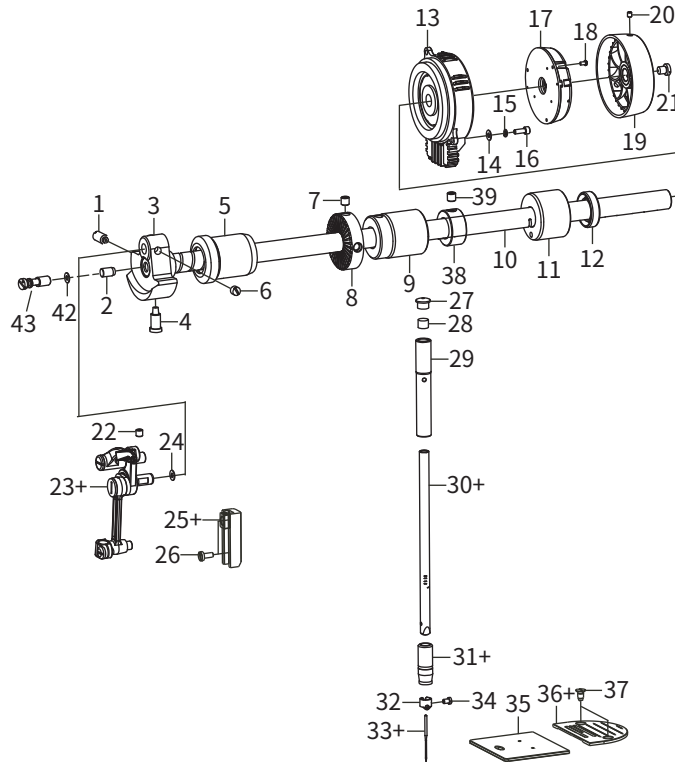

序號	圖號	數量	零件名稱	NAME OF PARTS	序號	圖號	數量	零件名稱	NAME OF PARTS
1	101031601	1	螺釘 SM7.14	SCREW PAN SM7.14	32	101041101	1	針杆過線環	NEEDLE BAR THREAD GUIDE
2	101034301	1	油量銷套	OIL QUANTITY PIN SLEEVE	33+	115024101	1	機針 DB×1 14	NEEDLE DB×1 #14
3	125031501	1	針杆曲柄	COUNTER WEIGHT	33+	115024102	1	機針 DP×5 20	NEEDLE DP×5 #20
4	101031801	1	螺釘 SM7.14	SCREW PAN SM7.14	34	101041001	1	支針螺釘 SM3.18	SCREW PAN SM3.18
5	168020501	1	上軸前軸套	MAIN SHAFT BUSHING FRONT	35	101011801	1	推板組件	SLIDE PLATE COMPONENTS
6	101031701	4	螺釘 SM6.35-40x6	SCREW SM6.35-40X6	36+	115023401	1	針板 M	THREAD PLATE M
7	014500832	2	螺釘 M5×8	SCREW PAN M5×8	36+	112023402	1	針板 H	THREAD PLATE H
8	101032101	1	繞線驅動輪	BOBBIN WINDER DRIVING WHEEL	37	115023501	2	螺釘 SM4.37	SCREW PAN SM4.37
9	168020901	1	上軸中軸套	BUSHING INTERMSDIATE	38	101032501	1	上軸擋圈	THRUST COLLAR
10	168023801	1	上軸	MAIN SHAFT	39	014770632	2	螺釘 SM6.35×40-6	SCREW SM6.35×40-6
11	168021101	1	上軸后軸套	MAIN SHAFT BUSHING READ	40	101030601	1	挑線杆防油套	OLL PROOF SLEEVE
12	115024001	1	油封	OIL SEAL	41	101032502	1	上軸擋圈	THRUST COLLAR
13	168021302	1	主軸電機組件	SERVO NOTOR ASSY	42	081004870	1	O型圈 6.5x1.5	O-RING 6.5X1.5
14	028050246	3	彈性墊圈 T5	SPRING WASHERT5	43	101034201	1	油量偏心銷	OIL QUANTITY ECCENTRIC PIN
15	025050132	3	墊圈 M5	WASHER M5					
16	018501432	3	螺釘 M5×14	SCREW PAN M5×14					
17	168023301	1	編碼器	FILM ROTATING AND ENCODER					
18	018300632	4	螺釘 M3×6	SCREW PAN M3×6					
19	115025303	1	手輪	HANG WHEEL ASM					
20	012501032	2	螺釘 M5×10	SCREW PAN M5×10					
21	115025401	1	螺釘 SM8.73	SCREW PAN SM8.73					
22	012061032	1	螺釘 M6×10	SCREW PAN M6×10					
23+	101031401	1	挑線杆組件 M	THREAD TAKE-UP LEVER ASM M					
23+	101031402	1	挑線杆組件 H	THREAD TAKE-UP LEVER ASM H					
24	115021402	1	墊圈 8	WASHER 8					
25	101043701	1	滑塊組件 M	SLIDE BLOCK SLOT ASSY M					
26	115024601	2	螺釘 SM3.57	SCREW PAN SM3.57×40-6					
27	115010801	1	橡皮塞 8.5	RUBBER CAP 8.5					
28	115025601	1	油氈	FELT					
29	101040301	1	針杆上套	NEEDLE BAR BUSH U					
30+	101040403	1	針杆 M	NEEDLE BAR M					
30+	101040404	1	針杆 H	NEEDLE BAR H					
31+	101040901	1	針杆下套 M	NEEDLE BAR BUSH D M					
31+	101040902	1	針杆下套 H	NEEDLE BAR BUSH D H					

1

2

3

4

5

SIRUBA PARTS LIST	Series	Parts Group	Subclass Remark	Page
	DL7500			1 / 1
				Date
				2022/01/13

3. 壓腳裝置/Presser foot mechanism

A

B

C

D

E

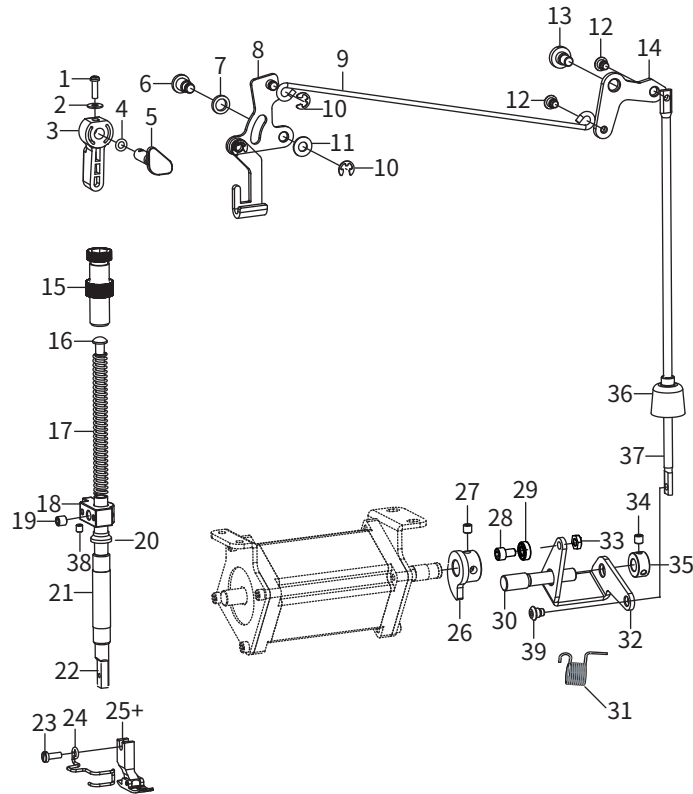

序號	圖號	數量	零件名稱	NAME OF PARTS	序號	圖號	數量	零件名稱	NAME OF PARTS
1	101054501	1	螺釘 SM3.57	SCREW SM3.57	38	115034201	1	抬壓腳減震墊	CUSHION
2	101054601	1	墊圈3.7	WASHER 3.7	39	168031301	1	軸位螺釘SM4.76x32	SCREW SM4.76x32
3	168030301	1	抬壓腳扳手	HAND LIFTER					
4	081004070	1	O型圈 P4	RING P4					
5	102050601	1	抬壓腳凸輪	PRESSER FOOT LIFTER CAM ASM					
6	101052001	2	前杠杆螺紋銷	LINK SHAFT					
7	101052101	2	防油橡膠墊(薄)	WASHER					
8	168031001-1	1	抬壓腳前杠杆	HANK LIFTER LINK					
9	168030901	1	抬壓腳拉杆	LIFTING LEVER LINK					
10	048050342	3	卡簧 E5	SNAP RING E5					
11	101056301	2	墊圈 6.35	WASHER 6.35					
12	115034301	2	軸位螺釘 SM4.76	SCREW SM4.76					
13	115034501	1	軸位螺釘 SM6.35	SCREW SM6.35					
14	115034601	1	膝控提升手杆	LIFT KNEE CONTROL LEVER					
15	168031501	1	調壓螺釘組件	PRESSURE REGULATING BOL					
16	101050301	1	調壓導杆	PRESSER GUIDE BAR					
17	125050401	1	調壓簧	PRESSER SPRING					
18	168031801	1	壓杆導架	NEEDLE BAR GUIDE BAACKET					
19	115024801	1	螺釘 SM6.35	SCREW SM6.35					
20	101050901	1	壓杆套防油圈	SHOCK PAD					
21	101051001	1	壓杆襯套	PRESSER BAR BUSHING LOWER					
22	101050501	1	壓杆	PRESSER BAR					
23	115031001	1	螺釘 SM3.57	SCREW SM3.57					
24	101051301	1	護指器	PROTECT SHELF					
25+	101051201	1	壓腳 M	MPRESSER FOOT ASM M					
25+	101051202	1	壓腳 H	MPRESSER FOOT ASM H					
26	168032701	1	抬壓腳凸輪	HAND LIFTER CAM					
27	014600832	2	螺釘 M6×8	SCREW PAN M6×8					
28	018601232	1	螺釘 M6×12	SCREW PAN M6×12					
29	169034001	1	軸承	BEARING					
30	168033101	1	抬壓腳曲柄軸	PRESSER FOOT CRANK SHAFT					
31	168033801-1	1	壓腳复位簧	PRESSER FOOT RESET SPRING					
32	168033201	1	抬壓腳驅動曲柄	PRESSER FOOT DRIVING CRANK					
33	021600306	1	螺母 M6×0.75	NUT M6×0.75					
34	014680632	2	螺釘 SM4.37-40x6	SCREW SM4.37-40X6					
35	168033501	1	曲柄軸擋圈	SET SCREW COLLAR					
36	168033601	1	膝控提升杆橡皮塞	RUBBER CAP					
37	168033701	1	抬壓腳頂杆	CONNECTING ROD VERTICAL					

1

2

3

4

5

SIRUBA PARTS LIST	Series	Parts Group	Subclass Remark	Page
	DL7500			1 / 1
				2022/01/13

4.送料装置/Feed mechanism components

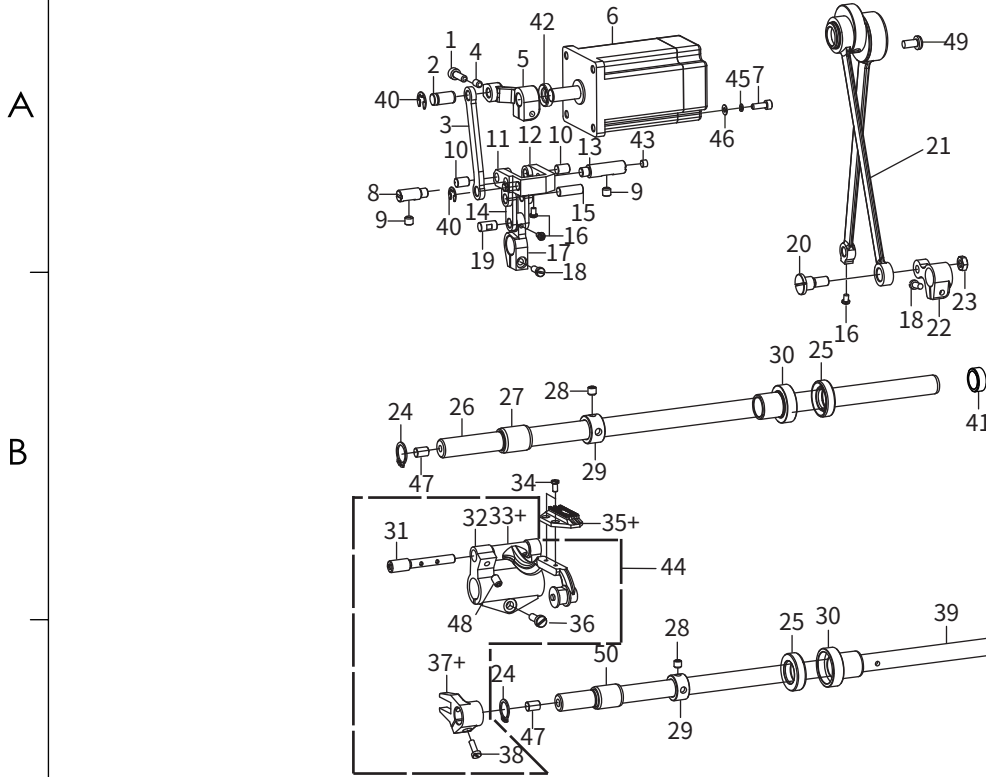

序號	圖號	數量	零件名稱	NAME OF PARTS	序號	圖號	數量	零件名稱	NAME OF PARTS
1	018501632	1	螺釘 M5×16	SCREW PAN M5×16	38	101064001	1	螺釘SM4.37-40x12	SCREW PAN SM4.37-40X12
2	168040201	2	連杆銷	STUD	39	168043901	1	抬牙軸	FEED DRIVING SHAFT
3	168040301	1	倒縫連杆	F-REGULATOR CONNECT ROD	40	048050342	2	卡簧 E5	RING E5
4	014680632	2	螺釘 SM4.37	SCREW PAN SM4.37	41	125013001	2	橡皮塞 15.2	RUBBER 15.2
5	168040501	1	倒縫曲柄	INVERTED CAANK	42	169041101	1	油封	OIL SEAL
6	168040602	1	倒縫步進電機	BACKSEWING STEPPING MOTOR	43	115011001	1	橡皮塞10.5	RUBBER STOPPER 10.5
7	018401632	4	螺釘 M4×16	SCREW PAN M4×16	44	101062101	1	牙架組件	TOOTH FRAME COMPONENTS
8	101061501	1	擺動板左銷	ADJUSTING LINK FULCRUM SHAFT	45	028040246	4	彈簧墊圈T4	WASHER T4
9	014760832	2	螺釘 SM5.95	SCREW PAN SM5.95	46	025040132	4	平墊圈4	WASHER 4
10	101061801	2	擺動板連接銷	FEED LINK STUD	47	115082801	4	油氈	LINOLEUM
11	168041101	1	切換器	LEVEL FEED REGULATOR	48	101062601	1	螺釘SM4.37-40x7	SCREW PAN SM4.37-40X7
12	101061602	2	曲柄短連杆	FEED ROCKER LINK	49	101060601	2	偏心輪螺釘	ECCENTRIC SCREW
13	168041301	1	切換器右銷	ADJUSTING LINK FULCRUM SHAFT	50	101063102	1	抬牙軸前軸套	FRONT BUSHING OF LIFTING SHAFT
14	101061701	2	曲柄長連杆	FEED ROCKER LINK					
15	101060901	1	送料連杆銷	WLSKING FOOT PIN					
16	101022801	5	螺釘 SM3.57	SCREW PAN SM3.57					
17	101063301	1	送料曲柄	FEED ROCKER SHAFT CRANK					
18	101063501	2	螺釘 SM4.76	SCREW PAN SM5.95					
19	101063401	1	送料曲柄銷	NWALKING FOOT PIN					
20	101061101	1	軸位螺釘SM7.14x28	HINGE SCREWSM7.14x28					
21	101060102	1	連杆組件 H	CONNECTING ROD ASM					
22	101063601	1	抬牙后曲柄	READ CRANK ASM					
23	101063701	1	螺母 SM5.95	NUT SM5.95					
24	048140142	2	擋圈 C14	RING C14					
25	125064301	2	油封	OIL SEAL					
26	168042601	1	送布軸	FEED ROCKER SHAFT					
27	101063101	1	送布軸前軸套	FEED ROCKER SHAFT METAL					
28	101063001	4	螺釘 SM6.35	SCREW PAN SM6.35					
29	101062901	2	送布軸擋圈	THRUST COLLAR					
30	168043001	2	送布軸中套	FEED ROCKER SHAFT METAL					
31	101062201	1	牙架銷	FEED BAR SHAFT					
32	101062501	1	牙架座	FEED ROCKER					
33	101062301	1	牙架	FEED BAR					
34	115047001	2	螺釘 SM3.18	SCREW PAN SM3.18					
35+	115046901	1	送料牙 M	FEED DOG M					
35+	115046902	1	送料牙 H	FEED DOG H					
36	101062701	1	螺釘 SM4.76	SCREW PAN SM4.76					
37	101063901	1	抬牙叉形曲柄	DRIVING SHAFT CRANK ASM					

1

2

3

4

5

SIRUBA PARTS LIST	Series	Parts Group	Subclass Remark	Page
	DL7500			1 / 1
				Date
				2022/01/13

5. 鍍梭裝置 / Hook components

A

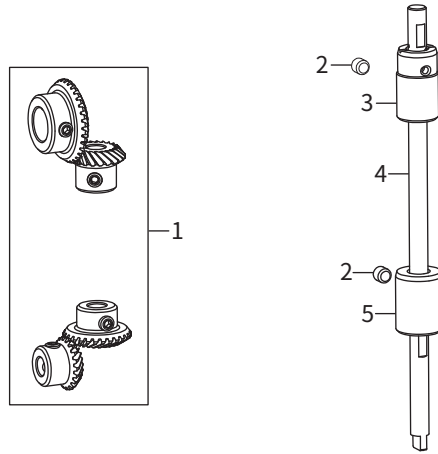

B

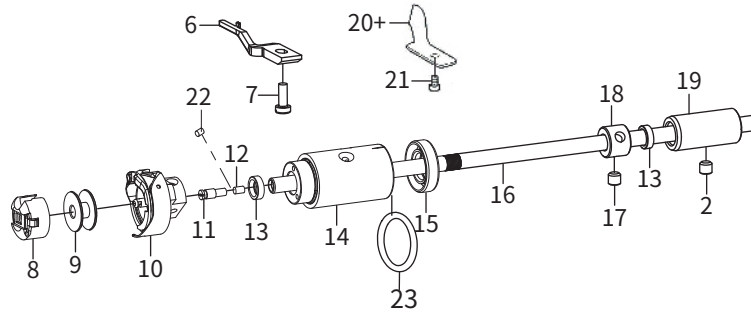

C

序號	圖號	數量	零件名稱	NAME OF PARTS
1	101041301	1	傘齒輪組件	BEVEL GEAR ASSY
2	014760832	3	螺釘 SM5.95	SCREW SM5.95
3	168050301	1	豎軸上軸套	VERTICAL SHAFT BUSH U
4	101041902	1	豎軸	VERTICAL SHAFT
5	168050501	1	豎軸下軸套	VERTICAL SHAFT BUSH D
6	115072204	1	鍍梭定位勾	HOOK STOPPER
7	125042401	1	螺釘 SM4.37	SCREW PAN SM4.37
8	115072701	1	梭芯套組件	BOBBIN GASE ASSY
9	115072401	1	梭芯	BOBBIN
10	115072301	1	鍍梭組件	ROTARY HOOK ASSY
11	115071401	1	油蓋螺釘	OIL COVER SCREW
12	125043201	1	油芯	OIL CORE
13	115073401	2	油封	OIL SEAL
14	168051401	1	下軸前套	PUMP BUSH
15	115071601	1	油封	OIL SEAL
16	101042901	1	下軸	ROTARY HOOK SHAFT
17	014770532	2	螺釘 SM6.35	SCREW PAN SM6.35
18	115072001	1	緊圈	SET SCREW COLLAR
19	168051901	1	下軸后軸套	BUSHING THREAD FINGER
20	125082201	1	分線片	LOWER THREAD FINGER
21	101080701	1	螺釘 SM3.57	SCREW PAN SM3.57
22	115073601	1	小油氈	FELT
23	115073301	2	O型圈	O-RING

D

E

SIRUBA PARTS LIST	Series	Parts Group	Subclass Remark	Page
	DL7500			1 / 1
				Date
				2022/01/13

6. 供油潤滑裝置/Lubrication

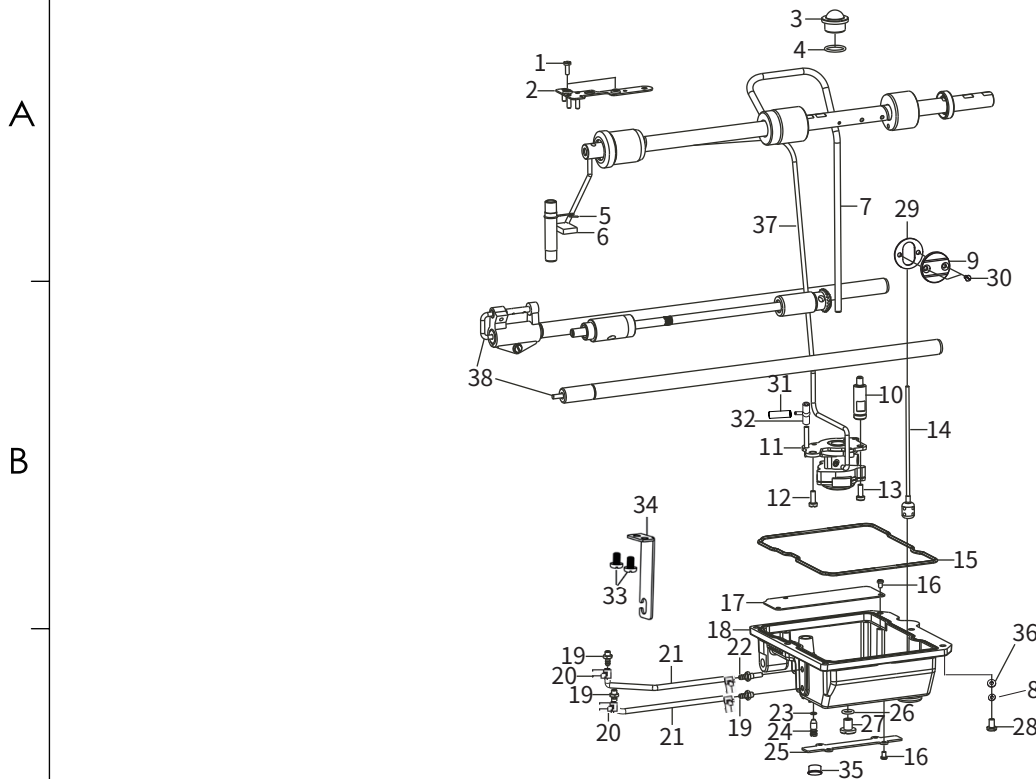

序號	圖號	數量	零件名稱	NAME OF PARTS	序號	圖號	數量	零件名稱	NAME OF PARTS
1	115031001	2	螺釘 SM3.57	SCREW SM3.57	37	5040202	1	尼龍油管3.2(670mm)	NYLON TUBING 3.2 (670MM)
2	101090701	1	油線固定板	OIL LINE FIXING PLATE	38	101092201	2	油線	OIL LINE
3	101090901	1	油窗	OIL WINDOW					
4	101091001	1	油窗墊片	OIL WINDOW GASKET					
5	101090601	1	油氈夾	LINOLEUM CLIP					
6	101090301	1	油氈	LINOLEUM					
7	101091801	1	上軸供油管	UPPER SHAFT OIL SUPPLY PIPE					
8	028050246	6	彈簧墊片T5	SPRING WASHER T5					
9	168063401	1	油量視窗板	OIL VOLUME WINDOW PANEL					
10	101091601	1	油泵連接螺釘	OIL PUMP CONNECTING SCREW					
11	168061401	1	油泵組件	OIL PUMP COMPONENTS					
12	101074701	1	螺釘 SM5.95	SCREW SM5.95					
13	115072601	1	螺釘 SM4.37	SCREW SM4.37					
14	180085401	1	浮球組件	FLOAT ASSEMBLY					
15	168061802	1	油盒密封圈	OIL BOX SEALING RING					
16	062350616	7	螺釘 M3.5×6	SCREW M3.5×6					
17	168062002	1	油盒蓋	OIL BOX COVER					
18	168062102	1	油盒	OIL BOX					
19	115080401	3	供油口	OIL SUPPLY PORT					
20	115085501	4	油管夾	TUBING CLAMP					
21	5040202	2	尼龍油管3.2(230mm)	NYLON TUBING 3.2 (230MM)					
22	168062601	1	供油口	OIL SUPPLY PORT					
23	081004870	1	O型圈 6.5x1.5	O-RING 6.5X1.5					
24	115081501	1	調節螺釘	ADJUSTING SCREW					
25	124123201	1	電線壓板	WIRE PRESSURE PLATE					
26	168063001	1	O型圈 13x2.4	O-RING 13X2.4					
27	115080901	1	放油螺釘 M8	OIL DRAIN SCREW M8					
28	018502032	6	螺釘 M5×20	SCREW M5×20					
29	168063501	1	油窗防油墊	OIL WINDOW OIL PAD					
30	115110401	2	螺釘 SM3.57×40-5	SCREW SM3.57×40-5					
31	125092201	1	鋁管接頭	ALUMINUM PIPE JOINT					
32	101091701	1	供油管接頭	OIL SUPPLY PIPE JOINT					
33	062500816	2	螺釘 M5×8	SCREW M5×8					
34	169080101	1	油管支架	TUBING BRACKET					
35	115011001	1	橡皮塞10.5	RUBBER STOPPER 10.5					
36	025050132	6	墊圈5	WASHER 5					

1

2

3

4

5

SIRUBA PARTS LIST	Series	Parts Group	Subclass Remark	Page
	DL7500			1 / 1
				Date
2022/01/13				

7.穿線裝置/Threading mechanism

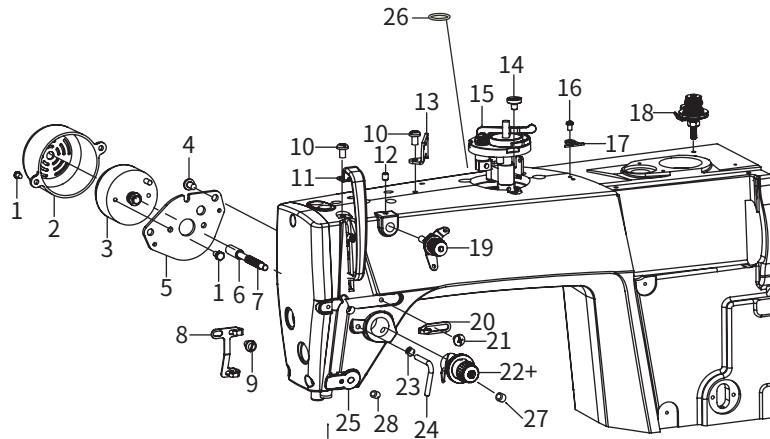

A

B

C

D

E

序號	圖號	數量	零件名稱	NAME OF PARTS
1	062400616	4	螺釘 M4×6	NEEDLE CLAMP SCREW PAN M4×6
2	168070201	1	電磁鐵罩	SOLENOID COVER
3	166070301	1	松線電磁鐵組件	ELEC TENSION RELEASE ASSY
4	062500816	2	螺釘 M5×8	SCREW PAN M5×8
5	168070802	1	電磁鐵安裝板	SOLENOID SETTING PLATE
6	168070901	1	松線銷	TENSION SHAFT
7	169122701	1	松線銷復位簧	TENSION RELEASE RETURN SPRING
8	180090201	1	面板線勾	FACE PLATE THREAD GUIDE
9	125022201	1	螺釘 M4×6	SCREW PAN M4×6
10	101010901	2	螺釘 SM4.76	SCREW PAN SM4.76
11	101010801	1	挑線杆防護罩	THREAD TAKE-UP LEVER COVER
12	101022201	1	螺釘 SM4.76	SCREW PAN SM4.76
13	115090301	1	穿線板	SPOOL PLATE
14	101022601	3	螺釘 M5×10	SCREW PAN M5×10
15	101022501	1	繞線器組件	BOBBIN WINDER ASM
16	101022801	2	螺釘 SM3.57	SCREW PAN SM3.57
17	101022701	1	割線刀	KNIFE
18	168072301	1	繞線器夾線組件	BOBBIN THREAD TENSION ASM
19	168072201	1	調線夾線器組件	THREAD TENSION ASM
20	101020701	1	右線勾	FRAME THREAD GUIDE R
21	101020201	1	螺釘 SM4.37-40x6	SCREW PAN SM4.37-40X6
22+	168072501	1	夾線器組件 M	THREAD TENSION ASSY M
22+	168072601	1	夾線器組件 H	THREAD TENSION ASSY H
23	115111601	1	螺母 SM4.37	SCREW PAN SM4.37
24	101020502	1	大線勾	P-BAR BRACKET THREAD GUIDE
25	166072501	1	電子夾線器	THREAD TAKE-UP
26	168072901	1	繞線器密封墊	WINDER GASKET
27	101020401	1	螺釘 SM5.95-28x7	SCREW PAN SM5.95-28X7
28	013760532	1	螺釘 SM5.95-28x5	SCREW PAN SM5.95-28X5

1

2

3

4

5

SIRUBA PARTS LIST	Series	Parts Group	Subclass Remark	Page
	DL7500			1 / 1
				Date
2022/01/13				

8.切線裝置/Thread trimmer mechanism

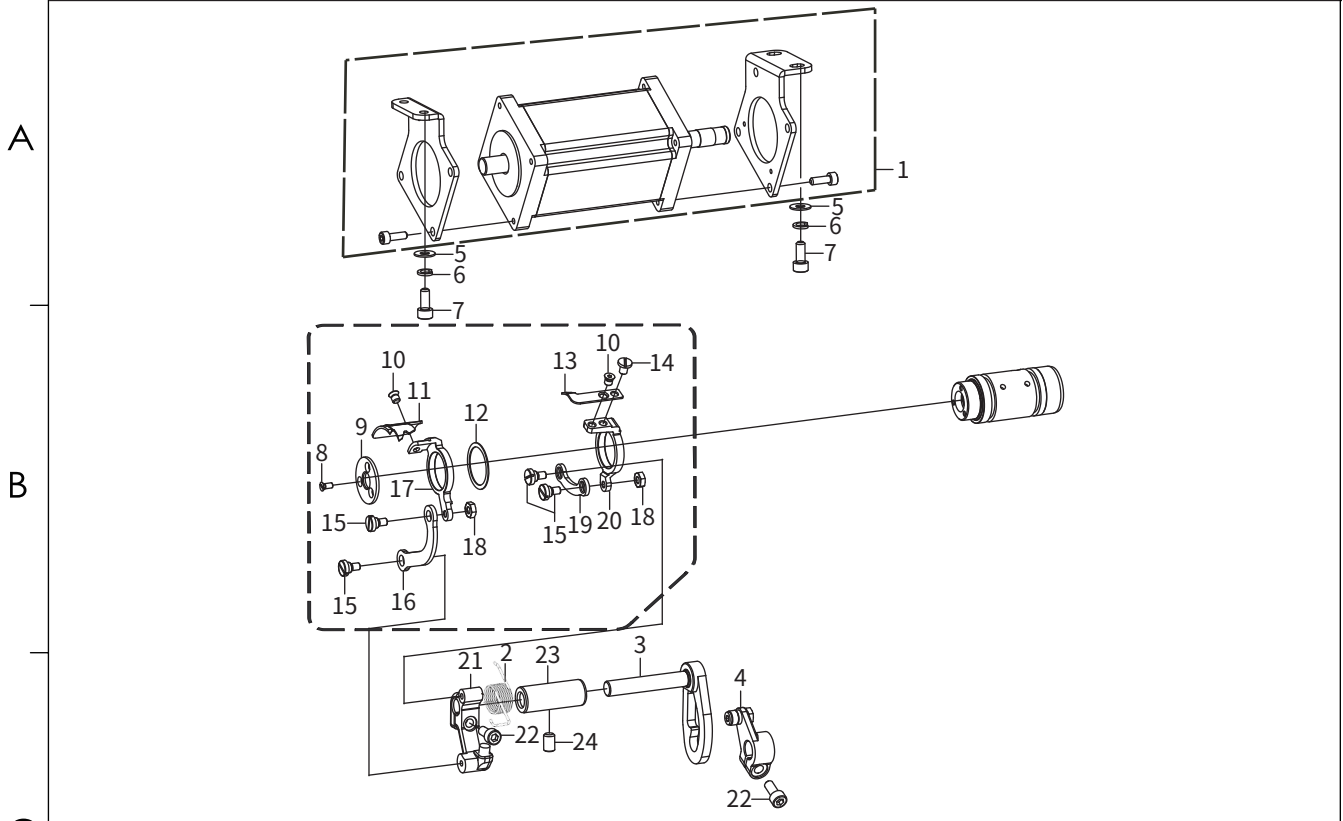

序號	圖號	數量	零件名稱	NAME OF PARTS
1	168080202	1	剪線電機	MOTOR
2	125082301	1	動刀復位簧	MOVBLE KNIFE RESET SPRING
3	168082001	1	切線曲柄	THREAD TRIMMER LEVER
4	169110102	1	切線驅動曲柄	THREAD TRIMMER CAM LEVER SHAFT
5	025050132	4	墊圈 M5	WASHER M5
6	028050246	4	彈簧墊圈	SPRING WASHER
7	018501432	4	螺釘 M5×14	SCREW PAN M5×14
8	125080401	3	螺釘 M3×7	SCREW PAN M3×7
9	125082501	1	動刀壓板	KNIFE HOLLDER PRESSER PLATE
10	115111301	3	螺釘 SM4.37	SCREW PAN SM4.37
11	125081501	1	下動刀	MOVABLE KNIFEL D
12	125081801	1	墊圈	WASHER
13	125081401	1	上動刀	MOVABLE KNIFEL U
14	125080501	1	螺釘 SM4.37	SCREW PAN SM4.37
15	125080601	4	螺釘 M4	SCREW PAN M4
16	125082001	1	刀架長連桿	KNIFE HOLLDER CONNECTING ROD L
17	125081701	1	下刀架	HOLER M-KNIFE D
18	021400306	2	螺母 M4	NUT M4
19	125081901	1	刀架短連桿	KNIFE HOLLDER CONNECTING ROD S
20	125081601	1	上刀架	HOLER M-KNIFE U
21	125082101	1	切線曲柄	THREAD TRIMMER LEVER
22	018501432	2	螺釘 M5×14	SCREW M5×14
23	115112301	1	叉軸軸套	FORKED SHAFT BUSH
24	014760832	1	螺釘 SM5.95	SCREW PAN SM5.95

SIRUBA PARTS LIST	Series	Parts Group	Subclass Remark	Page
	DL7500			1 / 1
				Date
				2022/01/13

9.倒縫開關裝置/Quick reverse switch mechanism

A

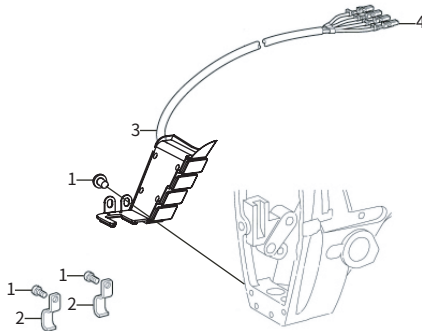

B

序號	圖號	數量	零件名稱	NAME OF PARTS
1	062500816	4	螺釘 M5×8	SCREW PAN M5×8
2	115114801	2	電線夾 U2	CORD HOLDER U2
3	166090302	1	倒縫開關組件	R-SWICH ASSY
4	168090401	1	10P插頭	10P PLUG

C

10.控制部分/Control components

D

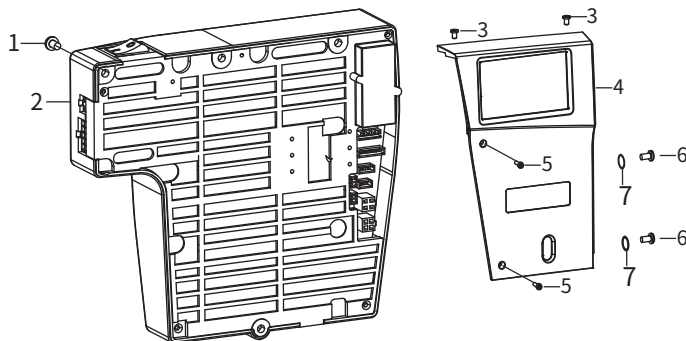

E

序號	圖號	數量	零件名稱	NAME OF PARTS
1	018501432	3	螺釘 M5×14	SCREW PAN M5×14
2	168101501	1	控制箱	CONTROL BOX ASSY
3	101020201	2	螺釘 SM4.37×40-6	SCREW PAN SM4.37×40-6
4	168100704	1	操作屏組件	OPERATION SCREEN COMPONENTS
5	168012501	2	螺釘 M3×8	SCREW PAN M3×8
6	062500616	2	螺釘 M5×6	SCREW PAN M5×6
7	025050132	2	平墊圈5	WASHER 5

SIRUBA PARTS LIST	Series	Parts Group	Subclass Remark	Page
	DL7500			1 / 1
				Date
2022/01/13				

11.附件/Accessories

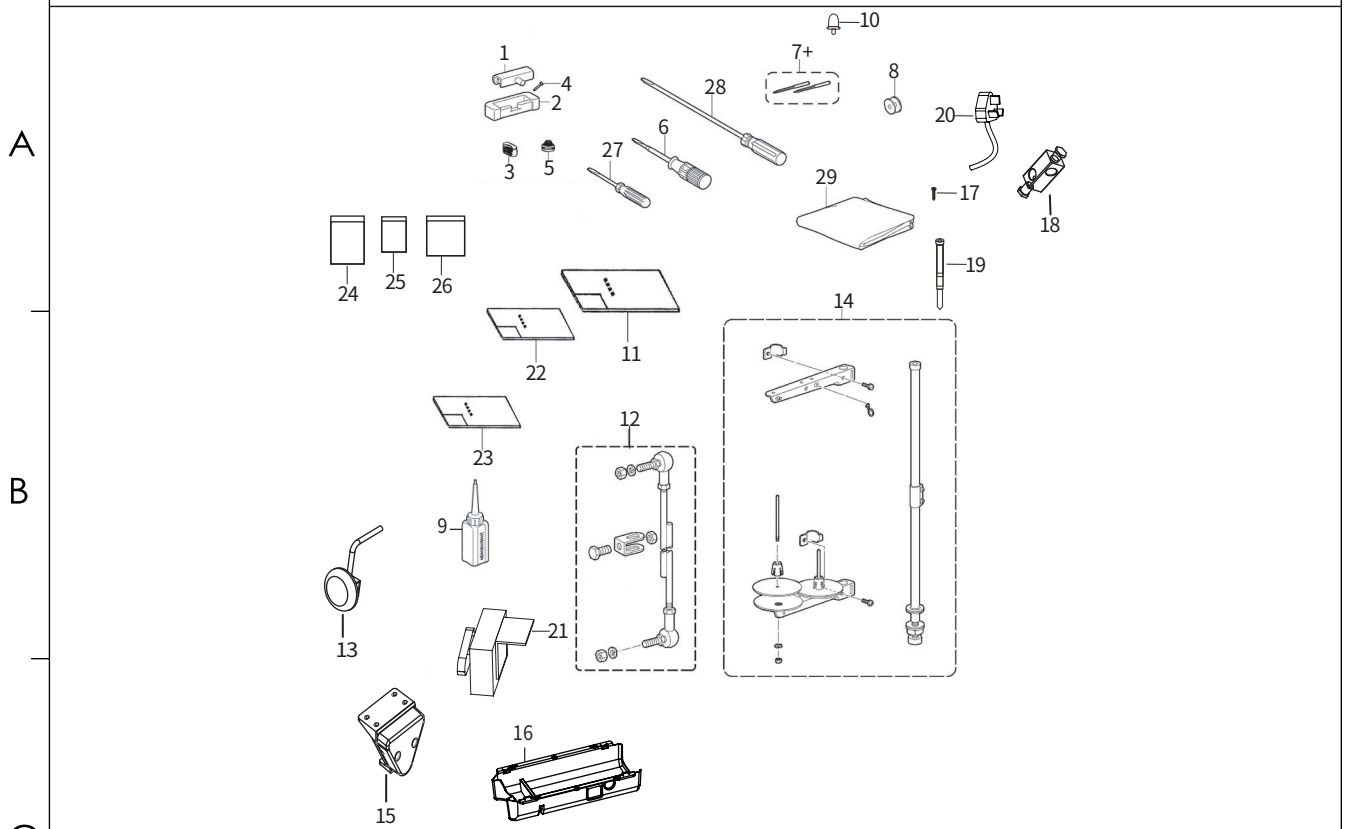

序號	圖號	數量	零件名稱	NAME OF PARTS
1	115150401	2	機頭絞鏈	MACHINE HEAD DUMPLING CHAIN
2	101120501	2	機頭絞鏈套	MACHINE HEAD DUMPLING CHAIN SLEEVE
3	125120601	2	頭部防震墊	HEAD SHOCK PAD
4	5050111	4	釘	NAIL
5	125120801	2	頭部防震墊	HEAD SHOCK PAD
6	115151701	1	螺絲刀(中)	SCREWDRIVER (MEDIUM)
7+	115024101	4	機針DB×1 14	NEEDLE DB×114
7+	115072102	10	機針DP×5 20	NEEDLE DP×520
8	115151001	3	梭芯	BOBBIN
9	115024113	1	中號油壺	MEDIUM OIL CAN
10	168111401	1	機頭撐杆	HEAD SUPPORT
11	6050270	1	零件手冊	PARTS MANUAL
12	115151901	1	連杆組件	CONNECTING ROD ASSEMBLY
13	125104001	1	膝控組件	KNEE CONTROL COMPONENTS
14	115151401	1	線架組件 2DR	WIRE RACK ASSEMBLY 2DR
15	169050101	1	電子膝靠組件	ELECTRONIC KNEE REST
16	125103101	1	油盤	OIL PAN
17	152208101	12	木螺釘ST4.2X25	WOOD SCREW ST4.2X25
18	125104101	1	膝控接頭	KNEE JOINT
19	5040104	3	扎帶	TIE
20	125122801	1	電源線	POWER CABLE
21	115152001	1	調速器	GOVERNOR
22	115151503	1	電控說明書	ELECTRIC CONTROL MANUAL
23	6050170	1	使用說明書	USER'S GUIDE
24	115160601	1	自封袋	ZIPLOCK BAG
25	115160701	1	自封袋	ZIPLOCK BAG
26	115160801	1	自封袋	ZIPLOCK BAG
27	115151601	1	螺絲刀(小)	SCREWDRIVER (SMALL)
28	115151801	1	螺絲刀(大)	SCREWDRIVER (LARGE)
29	6040101	1	機頭罩	HOOD

1

2

3

4

5

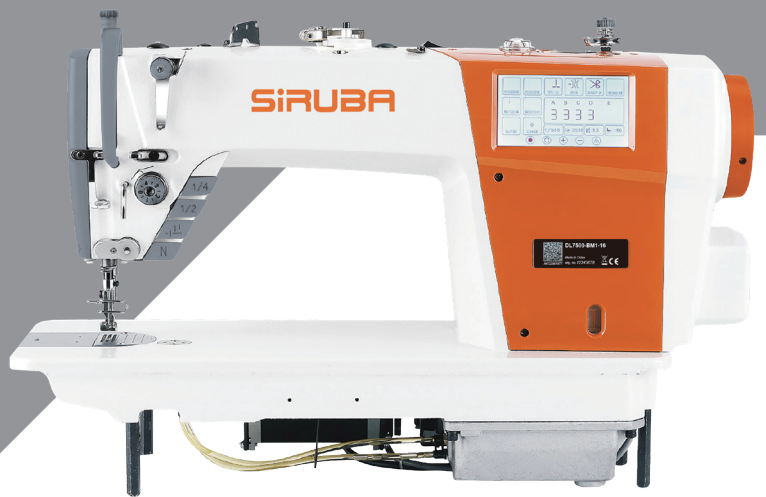

高林股份有限公司
KAULIN MFG. CO., LTD.

由於對產品的改良及更新，本產品使用說明書中與零件圖之產品及外觀的修改恕不事先通知！
The specification and/or appearances of the equipment described in this instruction book & parts list are subject to change because of modification which will without previous notice.
DL7500.JAN.2022